

Table of Contents

1	GENERAL NOTES	3
2	TECHNICAL DATA	4
3	DESIGN AND FUNCTION	5
4	SAFETY	6
5	TRANSPORT AND STORAGE	9
6	INSTALLATION	10
6.1	Mounting of the vibrator	10
6.2	Housing foot design with variable mounting pattern	11
6.3	Electrical connection	12
7	START UP / OPERATION	15
8	SERVICE / MAINTENANCE	16
9	ADJUSTMENT OF UNBALANCES	19
10	TROUBLE SHOOTING	22
11	SPARE PARTS	23
12	APPENDIX	24
12.1	Accessories	24
12.2	Disposal	24
12.3	Enclosures	24

Scope of delivery



Check the packaging for possible signs of transport damage. In the event of damage to the packaging, check that the contents are complete and undamaged. If there is any damage, inform the shipping agent. Compare the scope of the delivery with the delivery note.

1 General notes

Electric external vibrators of series NEA, NED and NEG from Netter comply with the EC machine regulation 98/37/EEC, the regulation concerning the electro-magnetic compatibility 93/97/EEC and the low voltage regulation 93/68/EWG. Standards EN 12100 part 1 and part 2, EN 50 081 part 2, EN 50 082 part 2 and EN 60 034 are especially complied with.

Netter series NEA and NEG electric external vibrators from housing size 100 comply with directive 94/9/EC for device group II and are suitable for use in potentially explosive areas of category 2 D in zones 21 and 22 (LCIE 07 ATEX 6015 X). Standards DIN EN 61241-0 and 61241-1 are especially complied with.

Electric external vibrators generate rotary vibration. These vibrators are intended for installation in machines and are employed to empty silos, to drive conveyor troughs, screens and vibrating tables, generally for loosening, conveying, compacting and separating of bulk materials and to reduce friction.

Before operating machines in which NEA and NEG vibrators are installed, it must be ensured that they comply with the requirements of the EC machine directive.

Applications in food and chemical industry are also possible when complying with the operating instructions of the operating company.









Before using these vibrators, the operator must ensure that there is no risk of explosion due to the introduction of vibration energy.

For applications in explosive environments explosion proofed electric external vibrators are available.

Special features:

- Adjustable centrifugal force
- All vibrators are impregnated for tropical use by vacuum casting or by trickle impregnation.
- 100% duty cycle (NEA 504, NEA 5020 and NEA 5050 60%)
- Degree of protection IP 66 (housing size 50 and 60: degree of protection IP 65)
- Insulation class F
- High rate of efficiency due to silicon electrical sheets
- Terminal box integrated in housing foot (housing size 101 to 120)
- Reduced installation dimensions
- Mounting foot multiple holed (housing size 50 to 120)
- Mounting foot with variable pattern (housing size 130)
- Stainless steel end covers (housing size 50 to 133)
- Sound level measured in the open ≤ 70 dB(A) acc. to IEC
- From housing size 170, equipped with PTC thermistor as standard.
- Earthing screw on housing and in terminal box

In these operating instructions the following information and danger symbols are used.

	Notes on important processes		Warning of hot surface
	Important note on processes to be especially observed		Disconnect unit from mains supply, pull out the mains plug
	Warning of a danger source		Environmental waste disposal
	Warning of dangerous electrical voltage		Important note on explosion protection

2 Technical Data

Mains voltage and frequency:

NEA and NEG series:

Voltage and frequency see details on type plate.

NED series: direct current 12 V or 24 V

Power supply by means of

- fixed voltage and frequency or
- frequency converter

The operation of three-phase vibrators of series NEG with frequency converters allows rotary speeds of > 3000 rpm.

If the electric external vibrators are operated with a frequency converter, compliance with the EMV-regulation must be observed.

In zones 21 and 22 the frequency converter may regulate the frequency between 20 Hz and 50 Hz or 20 Hz and 60 Hz (please check max. frequency on type plate) at a constant torque load (linear Volt-Hertz-curve).

Rotary speed ranges:

2-pole 3000 rpm 50 Hz / 3600 rpm 60 Hz

4-pole 1500 rpm 50 Hz / 1800 rpm 60 Hz

6-pole 1000 rpm 50 Hz / 1200 rpm 60 Hz

8-pole 750 rpm 50 Hz / 900 rpm 60 Hz

Direct current 3600 rpm



Ambient temperature:

-20°C to 40°C or

-20°C to 55°C

The ambient temperature specified at the type plate must not be exceeded nor fallen short of.

These values apply for operation with an ON-period of 100%.

For cycled or frequency controlled operation special regulations are valid. These must be settled with **NetterVibration** per individual case.

These electric vibrators must not be used in environments with a highly explosive gas atmosphere.

Thermal protection:

Starting with housing size 170, thermistors type PTC 130°C are standard. For smaller units available on request.

For smaller vibrators available as first equipment on request.

If the vibrator is operated in environments containing explosive dust (zone 21 and 22), it is mandatory to connect the PTC-thermistor.

This regulation does not apply if the unit is not equipped with a PTC-thermistor.

Sound level:

Depending on type ≤ 70 dB(A)

The noise level is determined to a great extent by the surface upon which the vibrator is mounted (e.g. sheet metal). The noise level will be amplified by non-silenced sheet metal.

Please refer to the type plate for the technical data of your electric external vibrator.

		NetterVibration Germany, 55252 Mainz-Kastel Tel.: +49 6134 2901-0			
Type designation	⇨	Type		Duty	%
Rotary speed	⇨	n	min ⁻¹	Fc	N
Voltage	⇨	U	V	f	Hz
Current	⇨	I	A	P	kW
Phases	⇨	Ph		Iso.Cl.	
Serial number	⇨	No.		Prot.	

- ⇨ Duty cycle
- ⇨ Centrifugal force
- ⇨ Frequency
- ⇨ Power
- ⇨ Insulation class
- ⇨ Degree of protection

		NetterVibration Germany, 55252 Mainz-Kastel, Tel. +49 6134 2901-0			
		0722 ID A21 IP66 T °C		Temperature class T (D)	
Type designation	⇨	Type	LCIE 07	Duty	100 %
Voltage	⇨	U	V	Fc	N
Current	⇨	I	A	n	min ⁻¹ Hz
Phases	⇨	Ph	Cap	P _{in}	kW
Capacity	⇨		µF	P _{out}	kW
Power factor	⇨	cos φ		Iso. Cl.	F
Year of manufacturing	⇨	Year		Prot.	IP66
Serial number	⇨	No.		Max. Amb.	40 °C

- ⇨ Duty cycle
- ⇨ Centrifugal force
- ⇨ Rotary speed
- ⇨ Frequency
- ⇨ Power input
- ⇨ Power output
- ⇨ Insulation class
- ⇨ Max. Ambient temperature

For detailed technical data on vibrators please refer to the charts in the middle section of these operating instructions (removable).

3 Design and function

- **The electric motor** for series NEA and NEG is an asynchronous motor, for series NED it is a DC motor.
 - To achieve a high rate of efficiency at a low temperature of the motor the stators of the asynchronous motors are made of electric sheet steel with a low dissipation factor.
 - The vacuum resin cast stators are a particular quality feature. The dried resin bonds housing and stator as an inseparable unit, which is robust and tropical proof. From housing size 140 the stators are trickle impregnated. With this method the spaces between the individual windings are completely filled and a vibration resistant seating of the complete unit is achieved.
 - Motor protection by installation of a PTC-thermistor 130°C, standard from size 170 (DIN 44081 und DIN 44082).
Protection by housing “tD” for use in areas with explosive dust atmosphere.
- **The motor shaft** is made of heat treated round alloy steel.
- **The special bearings** are over-dimensioned for excessive loads and high speeds.
- **For speed regulation** with frequency converters all units are suitable.
- **The housing of sizes 50 to 133** are made of an aluminium alloy.
- **The housing of sizes 140 to 210** are made of high-tensile nodular cast iron.
- Due to powder coating **the paint finish** is highly weather resistant as well as resistant against abrasion, impacts and a wide variety of chemicals. Colour: traffic black.
- **The unbalance masses** are adjustable:
 - Type XS infinitely
 - Type XM in 10% steps
 - Type XLs in 20° steps
 - Type XL removable discs
- Up to housing size 133 **the covers of the unbalances** are made of stainless high-grade steel, above size 133 of an aluminium alloy. (Paint: White aluminium).

4 Safety

Mains voltage and frequency:

NEA and NEG series:

Voltage and frequency see details on type plate.

NED series: direct current 12 V or 24 V

Power supply by means of

- fixed voltage and frequency or
- frequency converter

The operation of three-phase vibrators of series NEG with frequency converters allows rotary speeds of > 3000 rpm.

If the electric external vibrators are operated with a frequency converter, compliance with the EMV-regulation must be observed.

In zones 21 and 22 the frequency converter may regulate the frequency between 20 Hz and 50 Hz or 20 Hz and 60 Hz (please check max. frequency on type plate) at a constant torque load (linear Volt-Hertz-curve).

Rotary speed ranges:

2-pole 3000 rpm 50 Hz / 3600 rpm 60 Hz

4-pole 1500 rpm 50 Hz / 1800 rpm 60 Hz

6-pole 1000 rpm 50 Hz / 1200 rpm 60 Hz

8-pole 750 rpm 50 Hz / 900 rpm 60 Hz

Direct current 3600 rpm

Ambient temperature:

-20°C to 40°C or

-20°C to 55°C

The ambient temperature specified at the type plate must not be exceeded nor fallen short of.

These values apply for operation with an ON-period of 100%.

For cycled or frequency controlled operation special regulations are valid. These must be settled with **NetterVibration** per individual case.

These electric vibrators must not be used in environments with a highly explosive gas atmosphere.

Thermal protection:

Starting with housing size 170, thermistors type PTC 130°C are standard. For smaller units available on request.

For smaller vibrators available as first equipment on request.

If the vibrator is operated in environments containing explosive dust (zone 21 and 22), it is mandatory to connect the PTC-thermistor.

This regulation does not apply if the unit is not equipped with a PTC-thermistor.

Sound level:

Depending on type ≤ 70 dB(A)

The noise level is determined to a great extent by the surface upon which the vibrator is mounted (e.g. sheet metal). The noise level will be amplified by non-silenced sheet metal.



If the vibrator is operated in areas with explosive dust (zones 21 and 22):



- the external earthing has to be ensured via the static bonding connection at the foot of the housing and the mounting surface
- the frequency converter may regulate the frequency between 20 Hz and 50 Hz or 20 Hz and 60 Hz (please check max. frequency on type plate) at a constant torque load (linear Volt-Hertz-curve)
- it is mandatory to connect the existing PTC-thermistor
- it is not allowed to open the cover of the terminal block
- maintenance work is to be carried out at regular intervals by authorized and specialized staff with good knowledge of the standards EN 61241-17.



In zones 21 and 22 the external earthing has to be installed via the static bonding connection at the foot of the housing and the mounting surface.



The terminal box cover must not be opened in a potentially explosive area or during current flow.
If the terminal box cover or unbalance covers are opened, check the condition and correct positioning of the seals. Damaged seals must be replaced immediately.

WARNUNG  **WARNING**

Nicht öffnen in explosionsfähiger Atmosphäre.

Do not open in an explosive atmosphere



Live and rotating parts can cause severe or even deadly injury.
The operator of vibration machines must protect employees from actual or potential danger to their health and safety, due to the effect of vibrations.



The electric external vibrators are built in accordance with the latest EC directives.
Before using these vibrators, the operator must ensure that there is no risk of explosion due to the introduction of vibration energy.
The installation and operation of the vibrators is to be carried out in accordance with the ATEX regulations for operation in potentially explosive environments, the requirements of the local electrical engineering associations (e.g. VDE) and the familiar accident prevention rules.



Changes to the equipment may affect the characteristics of these electric external vibrators or even damage the units and cause the rejection of any warranty claims.
The non-observance of the instruction manual will also lead to the rejection of all warranty claims.



When working on the vibrator it must be isolated from the mains supply. To do so please proceed as follows:

1. Switch off the vibrator
2. Secure it against switching on
3. Make sure it is deenergized

Main switch
with padlock



The mains voltage and the mains frequency have to correspond to the nominal voltage and frequency indicated on the type plate. A voltage tolerance of $\pm 5\%$ or a frequency tolerance of $\pm 2\%$ are admissible.



Use a suitable flexible supply cable for the installation. Cable and protective conductor must be correctly connected. Circuit diagrams can be found in the terminal box (see chapt. 6.2 electric connection).



The condition of the ball and roller bearings must be regularly checked. The replacement of damaged bearings or bearings which have reached the end of their service life must be conducted by **NetterVibration**.



All electric cables must be properly routed. Make sure that the cable cannot be worn out by vibrating parts. The condition of the electric cables must be checked at regular intervals (normally every six months). Detected faults must be rectified immediately.
Protect the cable against high temperatures, lubricants and sharp edges.



Electric external vibrators of type NEG as well as part of the structure may come loose because of vibration. Falling parts can cause damage to persons and material. Screw retention devices and/or Loctite or similar must be used. Screw connections must be checked and, if necessary, retightened after 1 hour of operation and then at regular intervals (normally every month).

For reliable fastening we recommend the use of Netter NBS-screw connections (see chapter 6.1 „Fastening the vibrator“).
In critical installation situations the unit must be secured with a clamp and steel rope.



The vibrator must not be operated without the cover for the unbalances in place! The rotating unbalances cause a risk of injury!



The vibrator must not be touched during operation or shortly after switching off. The surface of the vibrator may become very hot during operation so that there is a risk of burning.



5 Transport and Storage



Check the packaging for possible shipping damage.
If damage to the packaging is found check the content for completeness and possible damage. In case of damage inform the forwarding agent.

The units are packed ready for installation. The name plate is attached to the vibrator. If not specified differently the vibrator is delivered with an unbalances setting of 100%.

When transporting the vibrator make sure not to subject the vibrator to extreme shocks which could damage the bearings.

The unit should be stored in a clean, dry environment. If the vibrator needs to be in storage for a longer period of time (2 years max.), the temperature in the store must not lie below +5°C or above +40°C and the relative air humidity must not exceed 60%.



If the vibrator is operated in areas with explosive dust (zones 21 and 22), a maintenance by **NetterVibration** is compulsory in case the unit was kept on stock for more than a year.



The transport eyes must solely be used to lift the vibrator.
If the vibrator is fitted with two transport eyes, both of these should be used for lifting. The lifting angle must not exceed 45°.



6 Installation



During installation please comply strictly with the safety regulations in chapter 4 and the safety regulations!
Installation of the system must be performed in compliance with the local, applicable regulations (e.g. VDE-regulations).

6.1 Mounting of the vibrator

Netter electric external vibrators can be operated in any position.
During installation the following notes must be strictly observed:



The mounting surfaces must be absolutely level ($\pm 0.1\text{mm}$ flatness fault), so that the feet of the vibrators have full area contact and to avoid warping of the housing when tightening the fastening screws. The surfaces should also be free of any paint residues and weld penetrations. Tensions in the housing can cause mechanical and/or electrical damage.

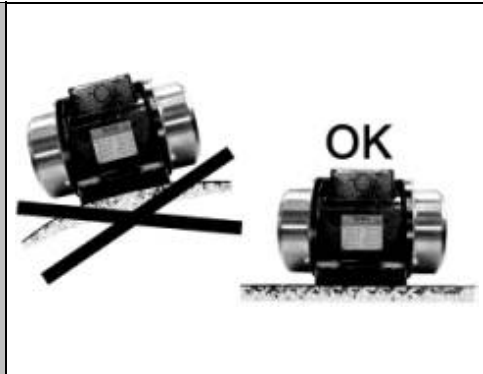

For safe fastening we recommend the use of Netter NBS screw connections consisting of screw, special lock washer and, if necessary, nut.

Otherwise the vibrators can also be fastened with fastening screws of quality 8.8 (DIN 931 or 933). These must be locked with qualified locking devices (DIN 934) and retightened at regular intervals (normally every month).



In critical installation situations the unit must be secured with clamp and steel rope.



The tightening torques can be taken from the following table. Higher tightening torques may cause fracture of screws or tearing of threads. Inadequate screw connections may cause loosening of vibrators by vibration. This can cause damage to persons and material!



Recommended tightening torques for screws property class 8.8 (screws as supplied, without additional lubrication):

Type of screw	M6	M8	M10	M12	M16	M20	M22	M24	M27
Tightening torque [Nm]	10,4	25	51	87	215	430	580	740	1100

Use a torque wrench and tighten the screws in a crosswise pattern.



Retightening:
Screw connections must be checked and, if necessary, retightened after 1 hour of operation (after initial commissioning) and then at regular intervals (normally every month).

6.2 Housing foot design with variable mounting pattern

Vibrators of housing size 130 have a variable fastening foot. This foot is equipped with 4 bushings, which can be rotated by 360°. The bushings enable an infinite adjustment of the fastening dimensions:

D from 92 to 128 mm and E from 167 to 203 mm.

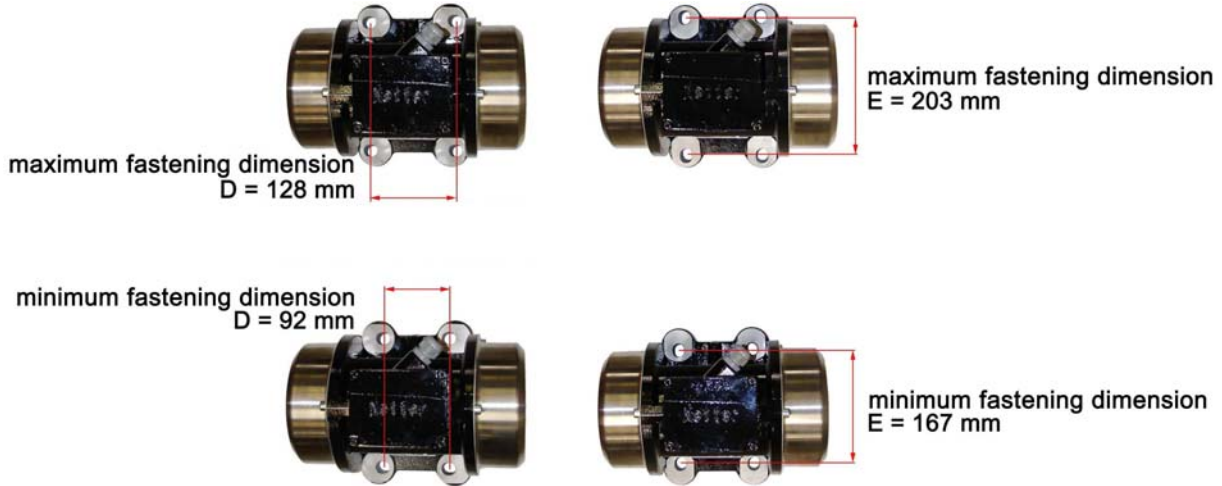

Variable fastening dimensions

In the table all dimension [mm] that can be adjusted by rotating the variable bushings are marked (X). Example: For D = **120** mm E = **195** mm.

E	92	93	94	95	96	97	98	99	100	101	102	103	104	105	106	107	108	109	110	111	112	113	114	115	116	117	118	119	120	121	122	123	124	125	126	127	128	D		
203																																								X
202																																								X
201																																								X
200																																								X
199																																								X
198																																								X
197																																								X
196																																								X
195																																								X
194																																								X
193																																								X
192																																								X
191																																								X
190																																								X
189																																								X
188																																								X
187																																								X
186																																								X
185																																								X
184																																								X
183																																								X
182																																								X
181																																								X
180																																								X
179																																								X
178																																								X
177																																								X
176																																								X
175																																								X
174																																								X
173																																								X
172																																								X
171																																								X
170																																								X
169																																								X
168																																								X
167																																								X

6.3 Electrical connection



ATTENTION:

The electrical installation of the vibrators must be conducted by authorized, qualified personnel only.

The terminal box must not be opened with electrical voltage applied!

The qualified personnel must use only insulated tools, which are suitable for the application.

Accessories, which guarantee correct operation and safety, must be equipped with a protection system suitable for the specific application.



When working on the vibrator it must be isolated from the mains supply. To do so please proceed as follows:

1. Switch off the vibrator
2. Secure it against switching on
3. Make sure it is deenergized

Main switch with padlock



The terminal box cover must not be opened in a potentially explosive area or during current flow.

If the terminal box cover or unbalance covers are opened, check the condition and correct positioning of the seals. Damaged seals must be replaced immediately.

WARNUNG  **WARNING**

Nicht öffnen in explosionsfähiger Atmosphäre.

Do not open in an explosive atmosphere



Each vibrator must be connected to a suitable overload protection. For dual operation, the motor protection switches must be interlocked to ensure that, in the event of one motor breaking down, the current supply is stopped from both motors simultaneously. This is to prevent uncontrolled vibrations arising, which could cause damage to the equipment.



In zones 21 and 22 the motor protection switches have to be approved for applications in potentially explosive areas.



The mains voltage and the mains frequency have to correspond to the nominal voltage and frequency indicated on the type plate. A voltage tolerance of $\pm 5\%$ or a frequency tolerance of $\pm 2\%$ are admissible.

Unbalance type XLs

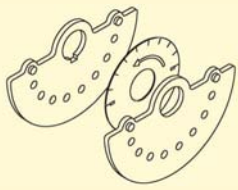

Unbalance type XS

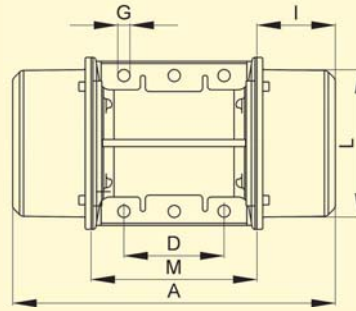
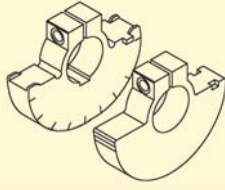

IV

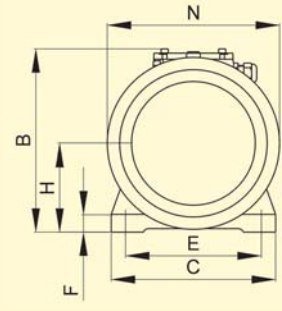

min ⁻¹	Type	Type of housing	Dimensions [mm]													Unbalance [No. of unbalance discs]																
			NEG NEA	A	B	C	D	E mounting pattern	F	G	H	I	L	M	N	n ₂	Typ	50 Hz	60 Hz													
3000 3600	NEG 501510	IV	428	235	232	140	190	25	17	104	86,5	188	248	224	4	XLs	12	8														
	NEG 501770										14						10															
	NEG 502020		16								10																					
	NEG 502270		18								12																					
	NEG 503400	IV	558	335	310	155	255	30	23,5	160	108	274	302	310	4	XLs	16	10														
	NEG 503820										18						12															
	NEG 506220		IV								670						380	390	200	320	32	28	189	155	340	352	384	4	XS	4	4	
	NEG 508830																							200						138	367	360
NEG 251370	IV	451	257	231	140	190	25	17	124,5	109,5	206	224	241	4	XS	4								4								
NEG 251760	IV	501	257	231	140	190	25	17	124,5	134,5	206	224	241	4	XS	4								4								
NEG 252060		573								170,5																						
NEG 252450	IV	535								283							278	155	225	28	22	140	136		236	255	271	4	XS	4	4	
NEG 253080		619																					178									
NEG 253720	IV	588	335	310	155	255	30	23,5	160		139	274	302	310	4	XS							4	4								
NEG 254310		670									180																					
NEG 254900	IV	640								369	340						180	280	30	26	173	155			302	322	340	4	XS	4	4	
NEG 256460	IV	670								380	390						200	320	32	28	189	155			340	352	384	4	XS	4	4	
NEG 258040	IV	629	395	392	200	320	35	28	192	135	355	270	375	4	XS	4	4															
NEG 258260	IV	862	436	460	125	380	35	38	215	230	387	320	414	6	XS	4	4															
NEG 2511210	IV	990	454	530	140	440	38	45	230	240	423	370	448	6	XS	4	4															
NEG 2513850																																
NEG 16780	IV	501																257	231	140	190	25	17	124,5	134,5	206	224	241	4	XS	4	4
NEG 161080	IV	573																257	231	140	190	25	17	124,5	170,5	206	232	241	4	XS	4	4
NEG 161470																																
NEG 161660	IV	619	283	278	155	225	28	22	140	178	236	255	271	4	XS	4	4															
NEG 162150																																
NEG 162550	IV	670																335	310	155	255	30	23,5	160	180	247	302	310	4	XS	4	4
NEG 163030		710																							200							
NEG 163820	IV	742	369	340	180	280	30	26	173	206	302	322	340	4	XS	4	4															
NEG 164700		802								236																						
NEG 165190	IV	772								380								390	200	320	32	28	189	206	340	352	384	4	XS	4	4	
NEG 166270		850																						245								
NEG 166670	IV	750	436	460	125	380	35	38	215		174	387	320	414	6	XS	4							4								
NEG 167890	IV	870	395	392	200	320	35	28	192		255	355	270	375	4	XS	4							4								
NEG 168500																																
NEG 169510	IV	862								436								460	125	380	35	38	215		230	387	320	414	6	XS	4	4
NEG 1612060	IV	990								454								530	140	440	38	45	230		240	420	370	448	6	XS	4	4
NEG 1613890	IV	960	526	570	140	480	41	45	268	200	495	510	516	8	XS	4	4															
NEG 1617000		1.040								240																						
NEG 1621960	IV	1.150								607								610	140	520	38	45	297	297,5	542	510	582	8	XS	4	4	
NEG 12440	IV	501								257								230	140	190	25	17	124,5	134,5	206	224	241	4	XS	4	4	
NEG 12610	IV	573	257	230	140	190	25	17	124,5	170,5	206	232	241	4	XS	4	4															
NEG 12930	IV	619	283	278	155	225	28	22	140	178	236	255	271	4	XS	4	4															
NEG 121430	IV	670	335	310	155	255	30	23,5	160	180	274	302	310	4	XS	4	4															
NEG 122150	IV	742	369	340	180	280	30	26	173	206	302	322	340	4	XS	4	4															
NEG 122640		802								236																						
NEG 122920	IV	772								380								390	200	320	32	28	189	206	340	352	384	4	XS	4	4	
NEG 123530		850																						245								
NEG 124440	IV	870	395	392	200	320	35	28	192		255	355	270	375	4	XS	4							4								
NEG 127640	IV	1.002	436	460	125	380	35	38	215		300	387	320	414	6	XS	4							4								
NEG 128520	IV	1.070	454	530	140	440	38	45	230	280	423	370	448	6	XS	4	4															
NEG 1211070	IV	1.040	526	570	140	480	41	45	268	240	485	510	516	8	XS	4	4															
NEG 1213160		1.120								280																						
NEG 1217670	IV	1.150								607								610	140	520	38	45	297	279,5	542	510	582	8	XS	4	4	



NetterVibration



Netter Electric-External Vibrators
 Series NEG 3-Phase
 Series NEA Single Phase
 Series NED Direct Current

Unbalance type XI Unbalance type XM Unbalance type XS



min ⁻¹	Type	Housing		Unbalance [cmkg]		Centrifugal Force [N]		EEx e II **	Power Input [kW]				Nominal Current [A]			
		Size	Material	NEG/NEA		NEG/NEA			NEG E	NEG		NEA		NEG		NEA
				50 Hz	60 Hz	50 Hz	60 Hz	50/60 Hz		50 Hz 400 V	60 Hz 480 V	50 Hz 230 V	60 Hz 115 V	50 Hz 400 V	60 Hz 480 V	50 Hz 230 V
3000 3600	NEA 504*	50	Al	0,08	0,08	40	57	-	-	-	0,024	0,024	-	-	0,13	0,30
	NEG/NEA 5020*			0,39	0,39	192	277		0,035	0,035	0,035	0,035	0,15	0,15	0,17	0,42
	NEG/NEA 5050*	60	Al	0,91	0,91	450	647	-	0,045	0,045	0,045	0,045	0,16	0,16	0,20	0,46
	NEG/NEA 5060	100	Al	1,22	1,22	602	867	-	0,12	0,12	0,165	0,165	0,27	0,23	0,75	1,52
	NEG/NEA 50120	101	Al	2,4	2,4	1.185	1.706	-	0,18	0,18	0,165	0,165	0,35	0,30	0,75	1,52
	NEG/NEA 50200			4,2	3,0	2.073	2.133									
	NEG/NEA 50300	110	Al	6,02	4,08	2.972	2.900	T3, T4	0,26	0,27	0,28	0,28	0,60	0,50	1,25	2,40
	NEG/NEA 50550	120	Al	9,97	6,48	4.921	4.606	T3, T4	0,45	0,50	0,5	0,5	0,80	0,75	2,30	4,50
	NEG/NEA 50770	130	Al	15,59	10,40	7.695	7.392	T3, T4	0,65	0,685	0,7	0,75	1,10	1,00	3,25	7,00
	NEG 50980 NEG 501140	133	Al	19,8 23,0	13,2 16,5	9.772 11.352	9.382 11.727	T3, T4	1	1,2	-	-	1,75	1,75	-	-
1500 1800	NEG 2530	101	Al	2,4	2,4	296	426	-	0,085	0,095	-	-	0,21	0,20	-	-
	NEG 2570			6,2	4,2	766	747									
	NEG 25210	110	Al	16,84	11,76	2.078	2.090	T4	0,17	0,17	-	-	0,41	0,40	-	-
	NEG 25420 NEG 25540	120	Al	32,64 43,80	22,66 32,64	4.028 5.405	4.027 5.800	T3, T4	0,30	0,35	-	-	0,60	0,60	-	-
	NEG 25700	130	Al	57,18	41,89	7.056	7.444	T3, T4	0,525	0,665	-	-	0,92	0,98	-	-
	NEG 25930	133	Al	75,0	52,0	9.254	9.239	T4	0,55	0,68	-	-	0,95	0,95	-	-
1000 1200	NEG 1630	110	Al	6,02	6,02	331	476	-	0,12	0,135	-	-	0,30	0,30	-	-
	NEG 1690			16,84	16,84	924	1.330									
	NEG 16190	120	Al	32,64	32,64	1.790	2.578	T4	0,185	0,205	-	-	0,50	0,50	-	-
	NEG 16310	130	Al	57,18	41,89	3.136	3.309	T4	0,35	0,38	-	-	0,72	0,68	-	-
	NEG 16410 NEG 16500	133	Al	75,0 90,7	52,0 66,5	4.113 4.974	4.106 5.251	T4 -	0,35 0,42	0,38 0,46	-	-	0,75 0,79	0,67 0,77	-	-
	NEG 12100	120	Al	32,64	32,64	1.007	1.450	T3	0,23	0,25	-	-	0,85	0,76	-	-
750 900	NEG 12180	130	Al	56,8	56,8	1.752	2.523	T3	0,35	0,38	-	-	1,10	1,05	-	-
	NEG 12230	133	Al	75,0	75,0	2.314	3.332	T4	0,28	0,30	-	-	0,60	0,68	-	-
	NED 50100	102	Al	2,0		987		-	0,13 (12 V =)		0,13 (24 V =)		11 (12 V =)		5,8 (24 V =)	
3000	NED 50200	103	Al	3,9		1.925		-	0,22 (12 V =)		0,22 (24 V =)		18 (12 V =)		9 (24 V =)	

* Protection IP 65, ** Technical Data available upon request

Unbalance type XLs

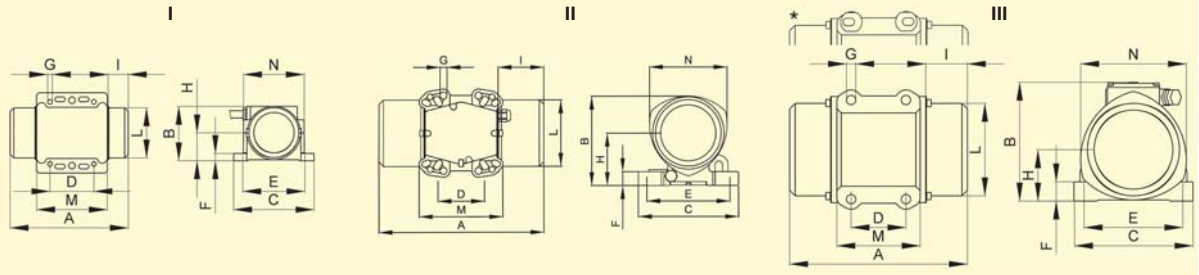
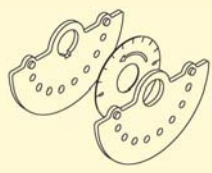

Type	Weight [kg]		Type of housing	Dimensions [mm]													Unbalance [No. of unbalance discs]			
	NEG/NEA			NEG NEA	NEG/NEA													NEG/NEA		
	50 Hz	60 Hz			A	B	C	mounting pattern**				H	I	L	M	N	n²	Typ	50 Hz	60 Hz
								D	E	F	G									
NEA 504*	0,90	0,90	I	113	62,5	90	25-40	75	9	5,5	32	20	56,6	70,5	75	4	XL	8	8	
NEG/NEA 5020*	1,75	1,70	I	154			60	85				27,5		85	4			8	8	
NEG/NEA 5050*	1,95	1,90	I	169	74,5	110	25-40	92	10	6,5	38	35	68,6	97	99	2	XL	18	18	
NEG/NEA 5060	4,8	4,8	II	197	121	126	60	100												
							62	95	20	9	72	33	92	88	105	4	XL	10	10	
							65	85												
							70	106												
NEG/NEA 50120	6,1	6,0	II	207			65	140		13										
							62-74	106		9		44						4	4	
							80	110		11	86		100	156	123	4	XM			
NEG/NEA 50200	6,7	6,5	II	223	143	165	115	135	25	11								4	4	
							135	115		11		52								
							124	110		11										
NEG/NEA 50300	10,3	10,1	II	247	172,5	165	65	140		13										
							80	110		11										
							115	135	25	11	103	50	124	156	146	4	XM	4	4	
							135	115		11										
							124	110		11										
							90	125		13										
NEG/NEA 50550	16,3	16,1	II	283	192	217	100	180	30	17	113	62,5	143	137	168	4	XM	4	4	
							105	140		13										
NEG/NEA 50770	22,3	21,3	III	308	212	238	100*	180*	43	17	93,5	63	168	163	193	4	XM	4	4	
							92-128*	167-203*												
NEG 50980	24,5	23,4	III				100	180	35	17	93,5	76	168	153	193	4	XM	4	4	
NEG 501140	25,0	24,0	II	324	216	219												4	4	
																		4	4	
NEG 2530	6,1	5,8	II	207	143	165	65	140		13										
							62-74	106		9		44								
							80	110	25	11	86		100	156	123	4	XM			
NEG 2570	7,3	6,9		243			115	135		11		62						4	4	
							135	115		11										
							124	110		11										
							65	140		13										
							80	110		11										
NEG 25210	12,8	11,8	II	307	172,5	165	115	135	25	11	103	80	124	156	146	4	XS	4	4	
							135	115		11										
							124	110		11										
							90	125		13										
NEG 25420	20,7	19,7	II	355	192	217	100	180	30	17	113	98,5	143	137	168	4	XS	4	4	
NEG 25540	22,7	21,7								105	140		13		116,5					
NEG 25700	29,4	28,4	III	392	212	238	100*	180*	43	17	93,5	105	168	163	193	4	XS	4	4	
							92-128*	167-203*												
NEG 25930	34,2	32,7	III	452	216	219	100	180	35	17	93,5	140	168	153	193	4	XS	4	4	
NEG 1630	12,0	10,1	II	247	172,5	165	65	140		13										
							80	110		11		50								
							115	135	25	11	103		124	156	146	4	XM	4	4	
NEG 1690	12,7	12,7		307			135	115		11		80								
							124	110		11										
							90	125		13										
NEG 16190	20,5	20,5	II	355	192	217	100	180	30	17	113	98,5	143	137	168	4	XS	4	4	
							105	140		13										
NEG 16310	28,9	27,9	III	392	212	238	100*	180*	43	17	93,5	105	168	163	193	4	XS	4	4	
							92-128*	167-203*												
NEG 16410	34,1	33,6	III	452	216	219	100	180	35	17	93,5	140	168	153	193	4	XS	4	4	
NEG 16500	36,1	35,1																		
NEG 12100	20,5	20,5	II	355	192	217	100	180	30	17	113	98,5	143	137	168	4	XS	4	4	
							105	140		13										
NEG 12180	28,0	28,0	III	392	212	238	100*	180*	43	17	93,5	105	168	163	193	4	XS	4	4	
							92-128*	167-203*												
NEG 12230	34,6	34,6	III	452	216	219	100	180	35	7	93,5	140	168	152	193	4	XS	4	4	
NED 50100		4,6	II	210	142	125	62-74	106	15	9	55	40	90	102	10	4	XLs	12	12	
							65	140		13										
							74	106	20	9	70	45,5	112	140	119	4	XLs	10	10	
NEG 50200		6,2	II	257	157	165	80	110		11										
							118	135		13										

* Variable mounting pattern see operating manual, ** Recommended mounting pattern in bold type.



Netter Electric-External Vibrators Series NEG 3-Phase

min ⁻¹	Type	Housing		Unbalance		Centrifugal Force		EEx e II **	Power Input		Nominal Current		Weight	
		Size	Material	50 Hz	60 Hz	50 Hz	60 Hz		50/60 Hz	50 Hz 400 V	60 Hz 480 V	50 Hz 400 V	60 Hz 480 V	50 Hz
3000 3600	NEG 501510	150	GGG	30,6	20,4	15.103	14.499	T3, T4	1,4	1,45	2,3	2,0	44	43
	NEG 501770			35,8	25,6	17.669	18.195	T3	2,0	2,0	3,3	2,9	45	44
	NEG 502020			41,0	25,6	20.236	18.195	T3	2,2	2,2	3,5	3,0	49	47
	NEG 502270	170	GGG	46,0	30,6	22.704	21.748	T3	2,2	2,2	3,5	3,0	50	49
	NEG 503400			68,8	43,0	33.957	30.561	-	3,8	3,8	6,2	5,4	106	102
	NEG 503820			77,4	51,6	38.202	36.673	-	4,0	4,0	6,5	5,6	107	103
	NEG 506220			126,0	88,6	62.189	62.970	-	5,5	5,5	9,2	8,0	188	181
NEG 508830	195	GGG	179,0	123,8	88.347	87.988	-	10,0	9,3	18,0	13,0	215	210	
NEG 251370	140	GGG	111,2	80,0	13.721	14.215	T3, T4	0,9	1,05	1,45	1,5	57	54	
NEG 251760	150	GGG	142,8	97,0	17.620	17.235	T3, T4	1,1	1,2	2,0	1,9	64	60	
NEG 252060			166,6	112,3	20.557	19.954	-	1,35	1,45	2,5	2,3	68	64	
NEG 252450	160	GGG	198,4	138,2	24.481	24.556	T3, T4	1,6	1,7	3,2	3,0	85	79	
NEG 253080			250,0	174,0	30.848	30.917	-	1,9	2,0	3,8	3,5	95	92	
NEG 253720	170	GGG	301,6	206,7	37.214	36.726	T3, T4	2,2	2,5	3,9	3,9	127	122	
NEG 254310			349,2	234,7	43.088	41.702	-	2,5	2,8	4,8	4,65	125	120	
NEG 254900	180	GGG	396,8	272,8	48.961	48.472	T3	3,6	3,4	6,0	5,0	174	166	
NEG 256460	190	GGG	523,8	364,6	64.632	64.783	-	6,0	6,0	10,5	9,0	212	200	
NEG 258040	195	GGG	652,0	452,0	80.450	80.312	-	10,0	9,3	18,0	13,0	215	210	
NEG 258260	197	GGG	669,2	492,4	82.573	87.490	-	7,5	8,5	12,2	12,0	317	303	
NEG 2511210	200	GGG	908,8	633,2	112.137	112.508	-	10,0	10,5	17,5	15,5	433	411	
NEG 2513850			1.122,8	825,2	138.542	145.981	-	11,0	12,0	20,0	20,0	458	424	
NEG 16780	140	GGG	142,8	111,8	7.831	8.829	T3, T4	0,68	0,76	1,4	1,35	60	55	
NEG 161080	150	GGG	196,4	142,8	10.771	11.277	T3, T4	0,75	0,75	1,65	1,5	70	61	
NEG 161470	160	GGG	267,8	187,4	14.686	14.799	-	1,0	1,0	1,8	1,7	81	74	
NEG 161660			303,1	198,4	16.622	15.668	T3, T4	1,1	1,3	2,6	2,8	96	86	
NEG 162150	170	GGG	392,8	275,0	21.541	21.717	-	1,5	1,7	3,0	2,75	105	93	
NEG 162550			464,2	323,0	25.457	25.507	T3	1,96	2,1	4,1	3,75	140	127	
NEG 163030	180	GGG	553,4	400,0	30.348	31.588	-	2,2	2,4	4,5	4,3	156	141	
NEG 163820			696,4	467,4	38.191	38.253	T3, T4	2,5	3,0	5,1	5,0	200	182	
NEG 164700	190	GGG	857,0	587,4	46.998	46.387	-	3,2	3,6	6,5	6,0	219	198	
NEG 165190			946,4	658,4	51.901	51.994	T3	3,8	4,0	7,0	6,5	247	225	
NEG 166270	197	GGG	1.142,8	795,0	62.671	62.781	-	4,3	5,0	8,2	8,1	279	251	
NEG 166670			1.216,6	795,8	66.718	62.844	-	5,0	5,9	10,0	9,8	285	257	
NEG 167890	195	GGG	1.439,4	993,4	78.937	78.448	-	7,0	7,5	9,6	13,0	320	282	
NEG 168500			1.550,4	1.077,0	85.024	85.050	-	7,5	8,2	14,0	12,9	326	289	
NEG 169510	197	GGG	1.734,6	1.132,8	95.125	89.457	-	4,6	8,0	13,5	12,4	381	340	
NEG 1612060	200	GGG	2.199,2	1.508,6	120.604	119.134	-	9,0	9,5	16,3	15,0	500	445	
NEG 1613890	205	GGG	2.532,4	1.740,0	138.877	137.407	-	10,6	11,3	19,0	18,0	643	605	
NEG 1617000			3.100,0	2.087,8	170.004	164.873	-	13,0	13,7	24,5	23,0	705	656	
NEG 1621960	210	GGG	4.005,0	2.510,6	219.634	198.261	-	19,0	19,0	33,0	25,5	926	896	
NEG 12440	140	GGG	142,8	142,8	4.405	6.343	-	0,4	0,45	1,2	1,2	60	60	
NEG 12610	150	GGG	196,4	196,4	6.058	8.724	T3	0,4	0,5	1,4	1,3	70	70	
NEG 12930	160	GGG	303,1	303,1	9.350	13.464	T3, T4	0,95	1,1	2,2	2,2	95	95	
NEG 121430	170	GGG	464,2	464,2	14.319	20.620	T3	1,5	1,79	4,1	4,2	133	133	
NEG 122150	180	GGG	696,4	696,4	21.482	30.934	T3	2,0	2,3	5,4	5,2	201	201	
NEG 122640			857,0	857,0	26.436	38.068	T3	2,5	3,0	6,0	6,0	217	217	
NEG 122920	190	GGG	964,4	964,4	29.194	42.839	-	2,8	3,35	6,5	6,5	242	242	
NEG 123530			1.142,8	1.142,8	35.253	50.764	T3	4,0	4,3	8,2	7,85	267	267	
NEG 124440	195	GGG	1.439,4	1.439,4	44.402	63.939	T3	4,9	5,8	9,9	9,5	320	320	
NEG 127640	197	GGG	2.478,0	2.194,6	76.440	97.485	-	6,8	7,5	13,2	12,0	438	419	
NEG 128520	200	GGG	2.763,2	2.481,4	85.238	110.225	-	7,6	8,3	14,0	13,5	540	520	
NEG 1211070	205	GGG	3.589,2	3.100,0	110.718	137.703	-	9,2	9,6	21,0	19,5	702	680	
NEG 1213160			4.267,4	3.812,8	131.639	169.366	-	10,4	11,2	22,0	20,0	755	711	
NEG 1217670	210	GGG	5.726,6	4.901,6	176.651	217.731	-	12,5	16,2	26,5	28,0	1015	981	

** Technical Data available upon request



The vibrator must only be connected using flexible cables.

The conductors in the feed cable for the connection of the vibrator to the mains supply must have a sufficient cross-section, suited to the length of the cable used.

The green-yellow conductor is the earthing conductor and must exclusively be used for connection to the earth terminal.

In zones 21 and 22 the external earthing is established via the earthing connection of the housing base and the mounting surface.



The ends of the leads must be fitted with isolated cable clips, to prevent the strands from splaying.

The maximum cable clip sizes are shown in the following list:

- Set screw M4 max. AWG 18
- Set screw M5 max. AWG 16
- Set screw M6 max. AWG 12
- Set screw M8 max. AWG 12

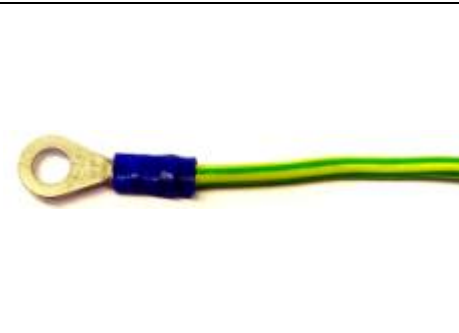

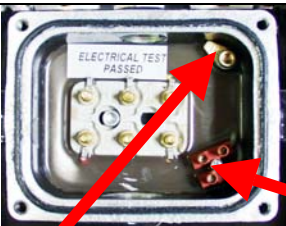
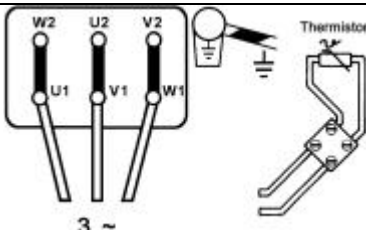
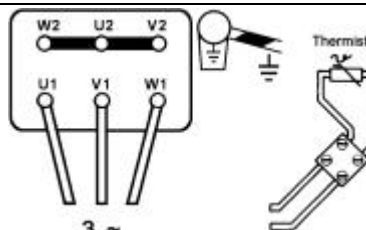
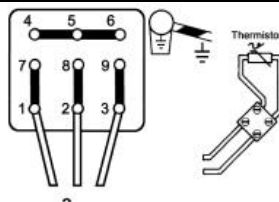
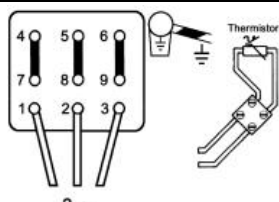
<p>In accordance with its connected voltage the circuitry specified in the terminal box must be connected as follows:</p>  <p>Thermistor</p>	Terminal plan III*	
	<p>Series NEG / Alternating current 3-phase Lower voltage Δ</p> 	<p>Higher voltage Y</p> 
<p>The green-yellow conductor is the earth conductor and must only be used for connection to the earth terminal.</p>	Terminal plan IV	
	<p>Series NEG / Alternating current 3-phase Lower voltage YY</p> 	<p>Higher voltage Y</p> 
<p>More terminal plans (e.g. for special voltages) on request.</p>		
<p>*The regulation for connection of the PTC-thermistor in areas with explosive dust (zones 21 and 22) is omitted for units which are not equipped with PTC-thermistor (standard fitting from housing size 170 upwards).</p>		



Tighten junction plate nuts using the prescribed torque. Be careful not to forget the safety washer between the ring and the nut and to replace the vibration-damping insert.

M 4 \Rightarrow 3.1 Nm

M 5 \Rightarrow 6.1 Nm

M 6 \Rightarrow 10.4 Nm

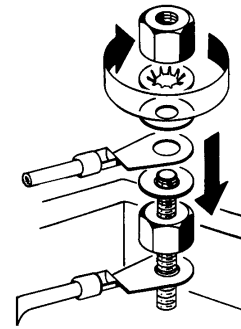

When selecting the connecting cables, please consider the mechanical demands on the cables due to vibration.

The recommended cable types for power supply operation with 400 V in non-explosive atmosphere: rubber hose line H07 RN-F or oilflex cable 110 CY.

In case of other voltages or other environmental conditions the cables have to be adapted and designed accordingly.



If the electric external vibrators are operated with a frequency converter, compliance with the EMV-regulation must be observed.



In zones 21 and 22 the frequency converter may regulate the frequency between 20 Hz and 50 Hz or 20 Hz and 60 Hz (please check max. frequency on type plate) at a constant torque load (linear Volt-Hertz-curve).



The electric lines have to be laid with care. It has to be avoided that the cables can be chafed through by vibrating parts.

The condition of the electric lines incl. plugs has to be checked at regular intervals (normally every six months). Defects which are discovered, have to be eliminated immediately.



Thermic overload protection:

Standard equipment with PTC-thermistor 130°C from housing size 170 upwards.

For smaller units available as first equipment on request.

If the vibrator is operated in environments containing explosive dust (zone 21 and 22), it is mandatory to connect the PTC-thermistor. This regulation does not apply if the unit is not equipped with a PTC-thermistor.

7 Start up / operation



Explosion-protected vibrators must only be used in atmospheres which will not damage the material of the device.

Observe the safety guidelines in Chapter 4 when starting up.



During commissioning of the vibrators the rules and regulations of local associations for electrical engineering (e.g. VDE) and the applicable accident prevention instructions must be observed.

During initial commissioning the current consumption must be measured individually in all three phases and should comply with the data on the type plate.



By adjusting the unbalances you can influence current consumption, centrifugal force and working moment, see chapter 9 „Adjustment of unbalances“.



ATTENTION:

The earthing screw labelled with the symbol \equiv is located inside the terminal box. This screw, which serves as **earthing connection** for the vibrator, must only be used to connect the protective conductor (green-yellow) of the power supply cable.



The terminal box cover must not be opened in a potentially explosive area or during current flow.

If the terminal box cover or unbalance covers are opened, check the condition and correct positioning of the seals. Damaged seals must be replaced immediately.

WARNUNG **WARNUNG**

Nicht öffnen in explosionsfähiger Atmosphäre.

Do not open in an explosive atmosphere

8 Service / Maintenance



When working on the vibrator it must be isolated from the mains supply. To do so please proceed as follows:

1. Switch off the vibrator
2. Secure it against switching on
3. Make sure it is deenergized

Main switch
with padlock



The following maintenance work has to be carried out at regular intervals by authorized and specialized staff with good knowledge of the standards EN 61241-17 (zones 21 and 22):

- a) Checking of the screwing connections
- b) Checking of the ball and roller bearings
- c) Relubricating of roller bearings
- d) Checking of operating hours (service life of bearings)
- e) Checking of cable supply line
- f) Replacement of o-rings and plastic seals every two years



Other maintenance and repair work are to be carried out by *Netter* Vibration exclusively.

Authorized and specialized staff is allowed to effect the following work on the vibrators:

The regulation of the unbalances incl. removal of the unbalance covers.

The electric connection incl. removal of the terminal block cover.

Please observe the safety instructions in chapter 4 when service on the unit is done.



Retightening:

Screw connections must be checked and, if necessary, retightened after 1 hour of operation (after initial start up) and then at regular intervals (normally every month). The specified torque must thereby be observed (see chapter 6.1).

Lubrication

Vibrators up to casing size 120 are equipped with ball bearings. These are lifetime lubricated (permanent lubrication).

From housing size 130 the units are fitted with roller bearings, these are lubricated with grease of type KLUEBER Staburags NBU 8 EP. This grease has the advantage that the bearings are lubricated for a period of at least 5000 operating hours (up to 3000 rpm). After this time the grease in the bearings must be completely renewed.

Vibrators with speeds exceeding 3000 rpm must be lubricated regularly in intervals of approx. 1000 operating hours.

Under severe operating conditions the lubrication intervals must be considerably reduced.

Service life of ball respectively roller bearings

If the vibrator is used in potentially explosive dust atmosphere, the operator has to control the condition of the bearings and the operating time of the complete unit. Vibrators with defective bearings or with bearings which have reached the end of service life, have to be sent to **Netter** Vibration for exchange immediately.

Grease quantity for lubrication and when replacing bearings

Type	Grease quantity [g]	Bearing lifetime 50 Hz [h]	Bearing lifetime 60 Hz [h]
NED 50100	Perm. lubrication	31800	
NED 50200	Perm. lubrication	4500	

NEA 504	Perm. lubrication	> 100.000	> 100.000
NEA 5020	Perm. lubrication	92.118	22.745
NEA 5050	Perm. lubrication	8.087	2.236
NEA 5060	Perm. lubrication	> 100.000	5.044
NEA 50120	Perm. lubrication	18.075	18.075
NEA 50200	Perm. lubrication	3.363	2.572
NEA 50300	Perm. lubrication	4.003	3.588
NEA 50550	Perm. lubrication	4.148	4.219
NEA 50770	8	6.439	6.146

NEG 5020	Perm. lubrication	92.118	22.745
NEG 5050	Perm. lubrication	8.087	2.236
NEG 5060	Perm. lubrication	> 100.000	5.044
NEG 50120	Perm. lubrication	18.075	18.075
NEG 50200	Perm. lubrication	3.363	2.572
NEG 50300	Perm. lubrication	4.003	3.588
NEG 50550	Perm. lubrication	4.148	4.219
NEG 50770	8	6.439	6.146
NEG 50980	9	5.062	4.833
NEG 501140	9	3.029	2.298
NEG 501510	16	4.038	3.856
NEG 501770	16	2.416	1.833
NEG 502020	30	7.070	8.372
NEG 502270	30	4.775	4.558
NEG 503400	40	8.672	10.267
NEG 503820	40	5.856	5.591
NEG 506220	120	5.743	4.636
NEG 508830	150	9.029	2.790

NEG 2530	Perm. lubrication	> 100.000	> 100.000
NEG 2570	Perm. lubrication	> 100.000	> 100.000
NEG 25210	Perm. lubrication	23.406	19.200
NEG 25420	Perm. lubrication	15.135	12.635
NEG 25540	Perm. lubrication	6.266	4.224
NEG 25700	8	17.199	11.997
NEG 25930	9	12.103	10.190
NEG 251370	16	10.870	8.330
NEG 251760	30	22.231	20.009
NEG 252060	30	14.300	12.300
NEG 252450	35	16.159	13.032
NEG 253080	35	7.100	5.900
NEG 253720	40	12.228	11.086
NEG 254310	40	8.200	7.300
NEG 254900	80	9.930	8.648
NEG 256460	120	10.478	8.451
NEG 258040	150	9.029	7.575
NEG 258260	180	11.460	7.881
NEG 2511210	260	10.576	8.718
NEG 2513850	300	9.000	6.200

Typ	Fettmenge [g]	Bearing lifetime 50 Hz [h]	Bearing lifetime t 60 Hz [h]
NEG 1630	Perm. lubrication	> 100.000	> 100.000
NEG 1690	Perm. lubrication	> 100.000	> 100.000
NEG 16190	Perm. lubrication	> 100.000	72.171
NEG 16310	8	> 100.000	> 100.000
NEG 16410	9	> 100.000	> 100.000
NEG 16500	9	> 100.000	39.516
NEG 16780	16	> 100.000	60.144
NEG 161080	30	54.020	42.632
NEG 161470	30	25.100	20.000
NEG 161660	30	29.165	29.270
NEG 162150	30	11.800	10.400
NEG 162550	32	17.701	12.292
NEG 163030	32	41.500	30.500
NEG 163820	60	13.073	10.842
NEG 164700	80	18.364	15.425
NEG 165190	100	19.206	15.157
NEG 166270	120	15.786	13.144
NEG 166670	120	13.767	14.000
NEG 167890	150	14.431	12.276
NEG 168500	150	11.266	9.379
NEG 169510	180	10.728	10.972
NEG 1612060	260	11.000	11.800
NEG 1613890	300	13.327	11.510
NEG 1617000	360	11.273	10.404
NEG 1621960	400	8.172	9.580

NEG 12100	Perm. lubrication	> 100.000	> 100.000
NEG 12180	8	> 100.000	> 100.000
NEG 12230	9	> 100.000	> 100.000
NEG 12440	16	> 100.000	> 100.000
NEG 12610	30	> 100.000	> 100.000
NEG 12930	30	> 100.000	65.414
NEG 121430	32	> 100.000	39.702
NEG 122150	60	> 100.000	29.320
NEG 122640	80	> 100.000	41.200
NEG 122920	100	> 100.000	43.076
NEG 123530	120	> 100.000	35.405
NEG 124440	150	> 100.000	32.368
NEG 127640	180	29.652	10.982
NEG 128520	260	52.762	18.667
NEG 1211070	300	37.822	15.233
NEG 1213160	360	35.257	12.684
NEG 1217670	400	22.520	9.347

Recommended tightening torques for screws (item 12 and item 22)

Type of screw	M6	M8	M10	M12	M14	M16	M18	M20
8.8 Tightening torque [Nm]	10,4	25	51	87	140	215	300	430
12.9 Tightening torque [Nm]	18	43	87	150	240	370	510	720

Recommended tightening torques for nuts (item 25)

Nuts	M5	M6	M10	M12	M14x1,5	M18x1,5	M24x2	M30x1,5
Nm	5	9	45	70	130	270	650	1100

Procedure to lubricate and replace the bearings:

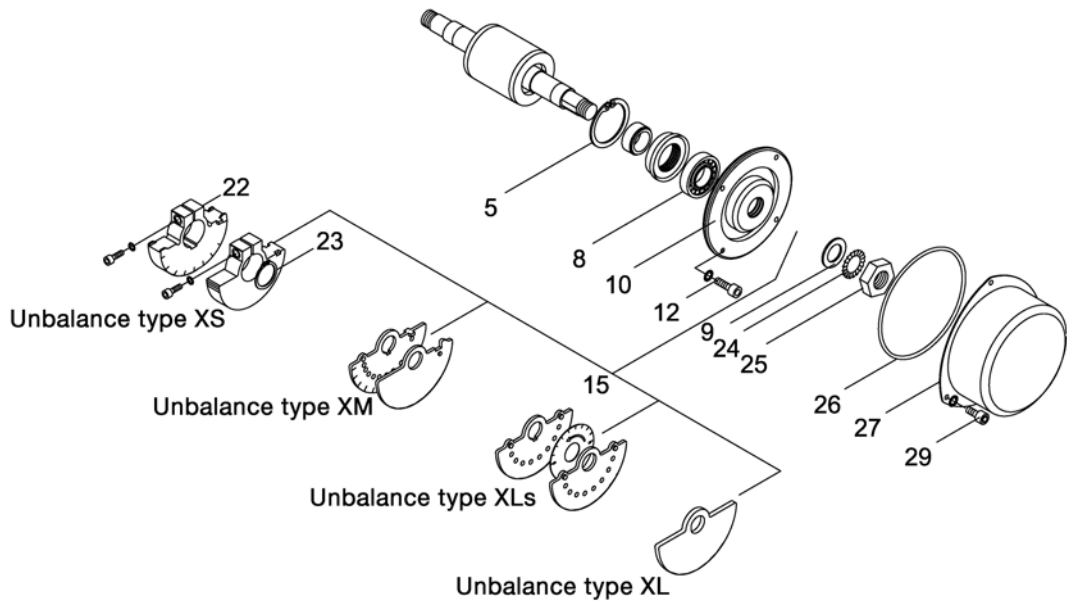

1. Switch off the vibrator, secure it reliably against switching on and make sure that it is dead.
2. Unscrew socket head cap screws (29) and remove covers (27) from the unbalances.
3. Disassembling the unbalances.

- Unbalances type XL, type XLs and type XM (15)

Screw a long screw with identical thread into a tapped bore for the fastening screws (29) of the cover for the unbalance. Place a chisel between unbalance discs and this screw. Loosen locking nut (25) (Fig. 1). The unbalances can be pulled off after unscrewing locking nut (25).

- Unbalances of type XS (15) (Fig. 2)

The unbalances can be pulled off after removing circlip (23) and loosening clamping screws (22).

4. Removing bearings (8):

- Up to housing size 120 remove circlip (5).
- From housing size 130 unscrew socket head cap screws (12) and disassemble flange (10). Remove circlip (5) from flange (10).

5. Replace both bearings (8) or clean off all old grease (e.g. with gasoline) and fill evenly with the specified quantity (table) of new grease (Klueber Staburags NBU 8 EP).

6. Assembly is performed in reverse order.

Tighten locking nuts (25) and socket head cap screws (12, 22) with the specified tightening torque.



Fig. 1



Fig. 2

9 Adjustment of unbalances



All vibrators of series NEA, NED and NEG offer the possibility of adjusting the unbalances.

If you have not specified any special data the units will be shipped with standard setting (100%).

By adjusting the unbalances you can directly influence the vibration amplitude, the centrifugal force and the current consumption.



On all units the unbalances must only be adjusted symmetrically mirrored!

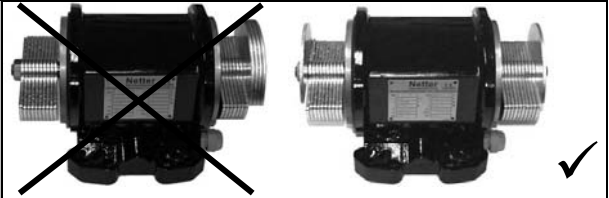

Listing of type and number of unbalances per vibrator at standard setting of 100%.

Type	Unbalance		
	Type	Number	
		12 V	24 V
NEA 50100	XLs	12	12
NEA 50200	XLs	10	10

Type	Unbalance		
	Type	Number	
		50 Hz	60 Hz
NEA 504	XL	8	8
NEA 5020	XL	8	8
NEA 5050	XL	18	18
NEA 5060	XL	10	10

NEA 50120	XM	4	4
NEA 50200	XM	4	4
NEA 50300	XM	4	4
NEA 50550	XM	4	4
NEA 50770	XM	4	4

Type	Unbalance		
	Type	Number	
		50 Hz	60 Hz
NEG 5020	XL	8	8
NEG 5050	XL	18	18
NEG 5060	XL	10	10

NEG 50120	XM	4	4
NEG 50200	XM	4	4
NEG 50300	XM	4	4
NEG 50550	XM	4	4
NEG 50770	XM	4	4
NEG 50980	XM	4	4
NEG 501140	XM	4	4

NEG 501510	XLs	12	8
NEG 501770	XLs	14	10
NEG 502020	XLs	16	10
NEG 502270	XLs	18	12
NEG 503400	XLs	16	10
NEG 503820	XLs	18	12

NEG 506220	XS	4	4
NEG 508830	XS	4	4

NEG 2530	XM	4	4
NEG 2570	XM	4	4

Type	Unbalance		
	Type	Number	
		50 Hz	60 Hz
NEG 25210	XS	4	4
NEG 25420	XS	4	4
NEG 25540	XS	4	4
NEG 25700	XS	4	4
NEG 25930	XS	4	4
NEG 251370	XS	4	4
NEG 251760	XS	4	4
NEG 252060	XS	4	4
NEG 252450	XS	4	4
NEG 253080	XS	4	4
NEG 253720	XS	4	4
NEG 254310	XS	4	4
NEG 254900	XS	4	4
NEG 256460	XS	4	4
NEG 258040	XS	4	4
NEG 258260	XS	4	4
NEG 2511210	XS	4	4
NEG 2513850	XS	4	4

NEG 1630	XM	4	4
----------	----	---	---

NEG 1690	XS	4	4
NEG 16190	XS	4	4
NEG 16310	XS	4	4
NEG 16410	XS	4	4
NEG 16500	XS	4	4
NEG 16780	XS	4	4
NEG 161080	XS	4	4
NEG 161470	XS	4	4
NEG 161660	XS	4	4
NEG 162150	XS	4	4
NEG 162550	XS	4	4
NEG 163030	XS	4	4
NEG 163820	XS	4	4
NEG 164700	XS	4	4
NEG 165190	XS	4	4
NEG 165580	XS	4	4
NEG 166270	XS	4	4
NEG 166670	XS	4	4
NEG 167890	XS	4	4
NEG 168500	XS	4	4
NEG 169510	XS	4	4
NEG 1612060	XS	4	4
NEG 1613890	XS	4	4
NEG 1617000	XS	4	4
NEG 1621960	XS	4	4

Type	Unbalance		
	Type	Number	
		50 Hz	60 Hz
NEG 12100	XS	4	4
NEG 12180	XS	4	4
NEG 12230	XS	4	4
NEG 12440	XS	4	4
NEG 12610	XS	4	4
NEG 12930	XS	4	4
NEG 121430	XS	4	4
NEG 122150	XS	4	4
NEG 122640	XS	4	4
NEG 122920	XS	4	4
NEG 123530	XS	4	4
NEG 124440	XS	4	4
NEG 127640	XS	4	4
NEG 128520	XS	4	4
NEG 1211070	XS	4	4
NEG 1213160	XS	4	4
NEG 1217670	XS	4	4

Procedure:

- Switch off the vibrator, secure it reliably against switching on and make sure that it is dead.
- Loosen both covers for the unbalances.
- Slacken the locking nuts or locking screws.
- Adjust the discs or cast iron unbalances as required.
- Tighten the locking nuts or locking screws.
- Reinstall the covers for the unbalances.

Unbalance discs type XLs

The unbalance setting of the unbalance discs of type XLs is made via the scale disc.

The centrifugal force is adjusted by turning the outer unbalance discs and adjusting them to the pitch lines on the scale disc.



Discs	4, 8, 12, 16	10	14	18
Setting	Centrif. force in %	Centrif. force in %	Centrif. force in %	Centrif. force in %
0°	100	100	100	100
20°	99	99	99	99
40°	94	94	94	94
60°	87	87	87	87
80°	76	78	77	77
100°	64	66	65	65
120°	50	53	52	51
140°	34	29	37	36
160°	17	26	22	21
180°	0	20	14	11

Unbalance discs type XM

The unbalance regulation of the unbalance discs type XM is effected via the scale of the fixed unbalance. The centrifugal force is set by turning the outer unbalance disc and by adjusting to the scale division lines. The regulation is possible in 10%-steps.



Unbalance discs type XS

The unbalance setting of the unbalance discs of type XS is made via the scale disc.

The centrifugal force is infinitely adjusted by turning the outer unbalance discs and adjusting them to the pitch lines on the scale disc. After adjusting the unbalances all nuts or screws must be retightened with the specified tightening torque.

With unbalance discs of type XS the centrifugal force can be adjusted according to the following table:

Setting	Centrifugal force in %
0°	100
15°	98,5
30°	97
45°	92
60°	87
75°	78,5
90°	70



Setting	Centrifugal force in %
105°	60
120°	50
135°	37,5
150°	25
165°	12,5
180°	0

Type of screw	M6	M8	M10	M12	M14	M16	M18	M20
8.8 Tightening torque [Nm]	10,4	25	51	87	140	215	300	430
12.9 Tightening torque [Nm]	18	43	87	150	240	370	510	720

For screw types M8 to M14 strength class 12.9 is used as standard

10 Trouble shooting



ATTENTION:

Faults on vibrators must only be repaired by authorized specialists.

Fault	Possible cause	Trouble shooting	Remedy
Vibrator does not start or runs with too low speed	Phase interruption	Check fuse and connecting cable	Replace fuse or connecting cable
	Mains voltage too low	Check mains voltage and cable cross-section	Correct mains voltage, replace cable
Vibrator speed drops under load	Wiring fault	Check with terminal plan	
	Insufficient contact on a connecting terminal	Check connection in terminal box	Tighten terminal nuts
	Phase interruption	Check fuse and connecting cable	Replace fuse or connecting cable
	Incorrectly dimensioned connecting cable	Check cable-cross section	Replace the cable
	Overload	Check setting of unbalances	Reduce the unbalance
One phase without current	Mains voltage too low	Check mains voltage and cable cross-section	Correct mains voltage, replace cable
	Phase interruption	Check the connecting cable	Replace the cable
Excessive heating of stator winding	Wiring fault	Check with terminal plan	
	Overload	Check mains voltage and cable cross-section	Correct mains voltage, replace cable
Vibrator humming	Mains voltage too low	Check mains voltage and cable cross-section	Correct mains voltage, replace cable
	Phase interruption	Check fuse, mains voltage and connecting cable	Correct mains voltage, replace fuse or cable
Circuit breaker fails when switched on	Turn-to-turn fault in the stator winding	Replace the vibrator	
	Phase interruption	Check fuse and connecting cable	Replace fuse or cable
	Overload	Check setting of unbalances	Reduce the unbalance
High current consumption	Short circuit in winding	Replace the vibrator	
	Natural resonance range of vibration system	Check the current consumption	Stiffen the device
	Impact	Check the current consumption	Reduce the power of the vibrator
Bearings overheating	Fastening loose	Tighten the screws	
	Too much grease in bearings	Fill in correct quantity of grease Klueber Staburags NBU 8 EP.	
	No grease in bearing	Fill in correct quantity of grease Klueber Staburags NBU 8 EP.	
	Foreign body in bearing	Clean bearing, replace if necessary.	

11 Spare Parts

When ordering spare parts you should always provide the following details:

1. Type of unit
2. Description and position of the spare part
3. Required quantity

12 Appendix

12.1 Accessories

The following accessories are available for electric external vibrators of series NEA, NED and NEG:

Description	Remark
Compensation washers	Compensation for removed unbalance discs
CC-unbalances	Two pre-adjusted working torques can be operated when changing the direction of rotation
Fastening sets NBS	for secure fastening of electric external vibrators
Frequency converters	for frequency regulated operation
Brake additives	enable a quicker braking of the vibrators
Special designs	Electric external vibrators are also available in special designs, e.g. for special voltages or for the use in explosive atmospheres. Information on request.
PTC thermistor	PTC 120°C thermistor for safe operation of the vibrators

Other electrical accessories on request.

12.2 Disposal

Depending on the material, the parts must be disposed of in an expert way.

Material specifications:

	NEA	NED	NEG housing types I, II and III	NEG housing types IV
Stainless steel	Covers for unbalances	Covers for unbalances	Covers for unbalances	
Steel	Rotor, unbalance , flange, bearings, screws, washers, nuts	Rotor, unbalance , flange, bearings, screws, washers, nuts	Rotor, unbalance , flange, bearings, screws, washers, nuts	Rotor, housing, unbalance , flange, bearings, screws, washers, nuts
Aluminium	Housing, type plate	Housing, type plate	Housing, type plate	Cover for unbalances, type plate
PTFE, PU, VITON	Seals terminal box block	Seals terminal box block	Seals terminal box block	Seals terminal box block
Copper with resin	Winding	Winding	Winding	Winding



All units can be disposed of through Netter GmbH.
The valid disposal prices are available on request.

12.3 Enclosures

Enclosure(s):

Declaration of manufacturer



**Further information available on request:
Brochure no. 8 (Netter Electric External Vibrators), and more.**