



These operating instructions apply to:

- PKL 190
- PKL 450
- PKL 740
- PKL 2100
- PKL 5000



Contents

1	GENERAL NOTES	3
2	SAFETY	5
3	TECHNICAL DATA	7
4	DESIGN AND FUNCTIONING	9
5	TRANSPORT AND STORAGE	10
6	INSTALLATION	11
7	START-UP / OPERATION	19
8	MAINTENANCE / REPAIR	20
9	TROUBLESHOOTING	21
10	SPARE PARTS	21
11	ACCESSORIES	22
12	DISPOSAL	23
13	ENCLOSURES	24

Scope of delivery

The PKL are delivered with the following components as standard:

- Pneumatic impactor (PKL)
- Operating instructions
- Packaging

For changes to the scope of delivery please refer to the delivery note.

Check the packaging for possible signs of transport damage. In the event of damage to the packaging, check that the contents are complete and undamaged. If there is any damage, inform the shipping agent. Compare the scope of the delivery with the delivery note.

1 General Notes

Information on the operating instructions

Use and storage of the operating instructions

Before use of the pneumatic impactors of the series PKL read this operating manual carefully. It is the basis for any action taken with regard to the PKL and may be used for training purposes. The operating manual should subsequently be stored near the PKL.

Target group

The target group of these operating instructions is qualified technical personnel from the mechanical engineering sector who have a basic knowledge of pneumatics and mechanics.

Installation, commissioning, maintenance, fault elimination and disassembly of the PKL must only be performed by persons who have been instructed in the proper handling of the units.

Persons who have not been instructed accordingly must not carry out any works on the PKL.

Copyright

This documentation is subject to copyright. All rights e.g. for translation, photo-mechanical reproduction, printing or reproduction (e.g. data processing, data carriers and data networks) of this operating manual, or parts thereof, are strictly reserved to **NetterVibration**.

Limitation of liability

All technical information, data and instructions on installation, operation and maintenance in these operating instructions are based on the latest information available at the time of printing and take into account our past experience to the best of our knowledge.





No claims can be derived from the information, illustrations and descriptions in these operating instructions.

The manufacturer does not assume liability for damages resulting from:

- failure to observe the operating instructions
- improper use
- unauthorized repairs
- technical modifications
- use of inadmissible spare parts

Translations are made to the best knowledge. **NetterVibration** does not assume liability for translation errors, even if the translation was made by us or on our behalf. Only the original German version is binding.

The following instruction and warning symbols are used in these operating instructions.

	DANGER	referring to a possible risk, which, if not avoided, can result in death or serious injury.
	CAUTION	referring to a possible risk, which, if not avoided, can result in serious injury and/or equipment damage.
	CAUTION: LOOSE PARTS	referring to a possible risk, which, if not avoided, can result in serious injury or equipment damage.
	IMPORTANT	note with especially useful information and tips.
	ENVIRONMENTALLY FRIENDLY DISPOSAL	refers to the obligation of an environmentally friendly disposal

Information on the PKLs

Netter pneumatic impactors series PKL comply with the EC machine directive 2006/42/EC.

In particular, standard DIN EN ISO 12100 has been observed.

Special features

- high impact force
- low air consumption
- reduced noise level due to elastomer insert

2 Safety

Designated use:

Impactors are intended for assembly into machinery where they are used to knock off stubborn residues from walls, to evacuate residues from weighing containers and to prevent bridging and rat-holing, as long as the material remains capable of flowing.

Any other use is considered improper use. There are no built-in safety devices

Qualification of the personnel:

Assembly, commissioning, maintenance and repair of the impactors must be performed only by authorized qualified personnel.

Any handling of the pneumatic impactors lies within the responsibility of the operator.

Accessories which ensure the correct operation and safety must provide a protection type required for the specific use.



CAUTION

Netter GmbH does not assume liability for damage or injury resulting from technical modifications to the product or failure to observe the instructions and warnings in this operating manual.

Source of danger:

Faulty hose connections.

Possible consequences of non-observance

A pressurized hose coming loose can cause severe injury.

Avoiding the danger:

The hose lines must be securely connected. This must be checked at regular intervals and the screw connections have to be retightened if necessary.

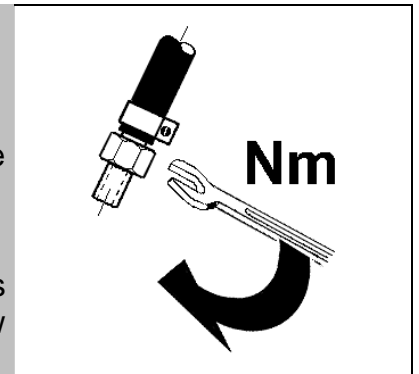

CAUTION

Source of danger:

PKL impactors work with compressed air.

Possible consequences of non-observance:

A pressurized hose coming loose can cause severe injury.

Avoiding the danger:

Ensure that the compressed air is shut off from the supply lines when working on the PKL.

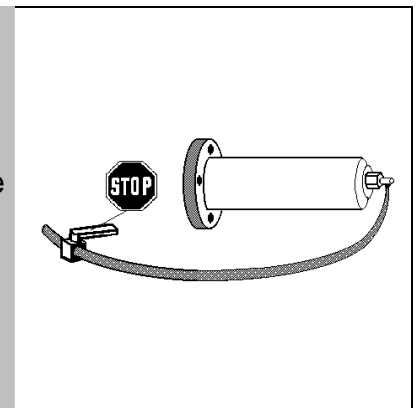

CAUTION

Source of danger:

Pneumatic impactors are not mechanically closed on the impact side. The impact piston and/or impact plate are loosely mounted.

Possible consequences of non-observance:

Falling parts can cause injury or material damage.

Avoiding the danger:

Ensure that the impact piston and/or impact plate remain in the housing during installation and disassembly!



CAUTION

Source of danger:

Impactors, parts of the construction and air connectors may become loose, due to vibration.

Possible consequences of non-observance:

Falling parts can cause material damage or injury.

Avoiding the danger:

Screw retention devices and/or Loctite or similar are to be used. Screwed connections and air connectors should be checked after 1 hour of operation and then at regular intervals (generally once per month) and tightened if necessary.

Netter fastening sets NBS are recommended for the attachment of impactors.

Pneumatic impactors PKL 450 should be installed with a dampening set; PKL 2100 and PKL 5000 must be mounted with a damper plate.

In critical installation situations it is required to secure the vibrator with a clamp and steel rope.

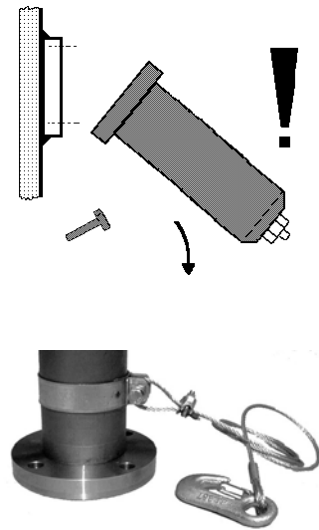

DANGER

Source of danger:

In the vicinity of the impactor, or structures connected to the impactor, the noise level can exceed 85 dB(A).

Possible consequences of non-observance:

Human hearing can be permanently damaged by the high noise level.

Avoiding the danger:

When working in the noise area, ear defenders are required if the sound level exceeds 85 dB(A).

Preferably the PKL should be installed with the EE kit.



CAUTION

3 Technical Data

Type	Weight of piston [kg]	Force of impact* [kg]	Optimum operating pressure [bar]	Air consumption/ impact at optimum pressure [Normal liter]	Overall weight [kg]	Suitable for wall thickness of [mm]
PKL 190/4	0,19	0,43	4,0	0,09	0,8	1 – 2
PKL 190/6	0,19	0,60	6,0	0,14	0,8	1 – 2
PKL 450/4	0,44	0,56	4,0	0,13	1,6	1 – 3
PKL 450/6	0,44	0,92	6,0	0,18	1,6	1 – 3
PKL 740/3	0,74	1,30	3,0	0,27	2,6	2 – 4
PKL 740/4	0,74	1,80	4,0	0,38	2,6	2 – 4
PKL 740/5	0,74	2,10	5,0	0,43	2,6	2 – 4
PKL 740/6	0,74	2,70	6,0	0,54	2,6	2 – 4
PKL 2100/4	2,10	4,20	4,0	1,55	6,7	3 – 5
PKL 2100/5	2,10	6,20	5,0	1,93	6,9	3 – 5
PKL 5000/4	4,96	6,60	4,0	1,50	16,0	4 – 8
PKL 5000/6	4,96	10,60	6,0	2,20	16,5	6 – 12

*The impact force corresponds to the impact of the indicated weight falling from a height of 1m.

Admissible operating conditions

Drive medium

Clean (Filter $\leq 5 \mu\text{m}$, quality class 3 according to DIN ISO 8573-1), lubricated compressed air or lubricated nitrogen.

Lubrication

Fill mist lubricator with acid- and resin-free pneumatic oil, ISO viscosity class according to DIN 51519, VG 5 to VG 15.
Recommendation: Klüber „AIRPRESS 15" for temperatures up to 60°C.

Operation in a dusty environment is possible.

In consultation with **NetterVibration** the PKL can also be operated without lubrication.



IMPORTANT

Operating pressure

Operating pressures between 2.5 bar and 7.0 bar are possible.
The actual air pressure set on the regulator must not exceed the optimum pressure by more than 1 bar (maximum pressure).

Frequency of impacts

A maximum of 10 impacts in a row at an impact frequency of 15 impacts/min and 180 impacts/h.

This impact sequence must not be exceeded.

Ambient temperature

-20°C to 60°C

HT version: -20°C to 160°C

The admissible ambient temperatures must not be exceeded or fallen short of during operation.

*) Higher operating pressures and temperatures are only possible following consultation and written permission from Netter GmbH application engineers.

Type designation

The type designation of PKL impactors has the suffix /3, /4, /5 or /6. These numbers are derived from the optimum operating pressure, i.e. the PKL 740/4 works most effectively at a pressure of 4 bar.

Operating time

The technical performance data will change in the course of the operating time (wear).

Noise level

Preferably the PKL should be installed with the EE kit. This reduces the impulse (rubber hammer effect). With this kit the noise level is around 75 dB(A) (individual sound event).

Depending on the impact sequence the continuous noise level is below this value.

The sound emitted by the PKL can be dampened by a cover (upon request). This only makes sense if the impacted sheet metal is also dampened (e.g. by heat insulation material).

Dimensions

PKL 190

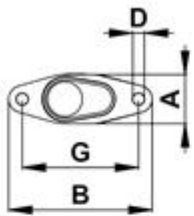

PKL 450

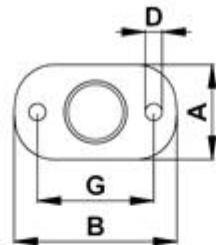

PKL 740

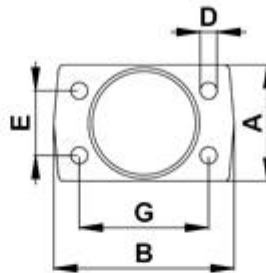

PKL 2100
PKL 5000

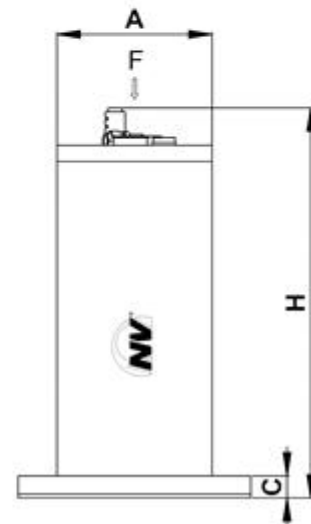
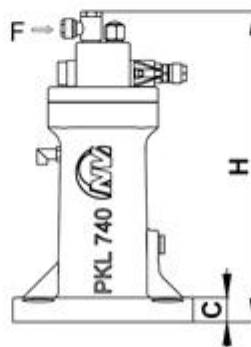
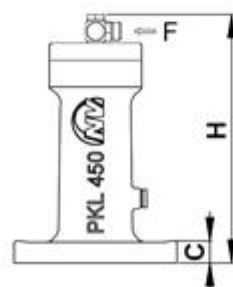
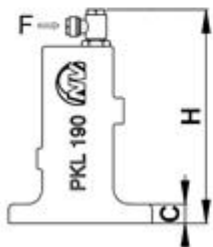
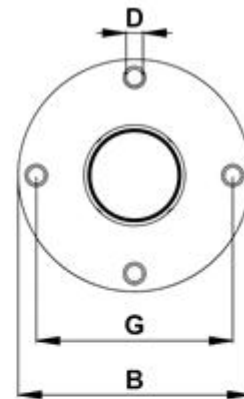

Type	A [mm]	B [mm]	C [mm]	Ø D [mm]	E [mm]	F	G [mm]	H [mm]
PKL 190	38	111	15	9,0	—	G 1/8, NW 6 × 1	90,0	163,5
PKL 450	73,5	126	14	13,0	—	G 1/8, NW 6 × 1	90,0	192,0
PKL 740	90	140	15	13,0	50	G 1/8, NW 6 × 1	100,0	238,5
PKL 2100	Ø120	Ø180	17	13,0	—	G 1/8, NW 6 × 1	Ø152	301,5
PKL 5000	Ø114,3	Ø180	22	17,0	—	G 1/8, NW 6 × 1	Ø152	376,5

4 Design and Functioning

The pneumatic interval impactor is a pneumatic “hammer”.

Compressed air P flows beneath the piston C and pushes it against one or two springs B.

Upon exhaust, the air chamber below the piston is emptied all at once.

The piston C (hammer) is shot against an elastomer (EE kit) or against an impact plate E by the springs, and the plate transfers the blow F.

If no Elastomer is used, the piston hits directly against the mounting surface. In the standard versions the impact plate is always made of steel and can be replaced by an Elastomer impact plate.

The air is evacuated via the silencer A.

The unit is attached via flange D by four fastening screws. (PKL 190 and PKL 450 2 fastening screws).

Pneumatic impactors only work after assembly, since the piston chamber is then sealed by an o-ring installed in the contact surface.

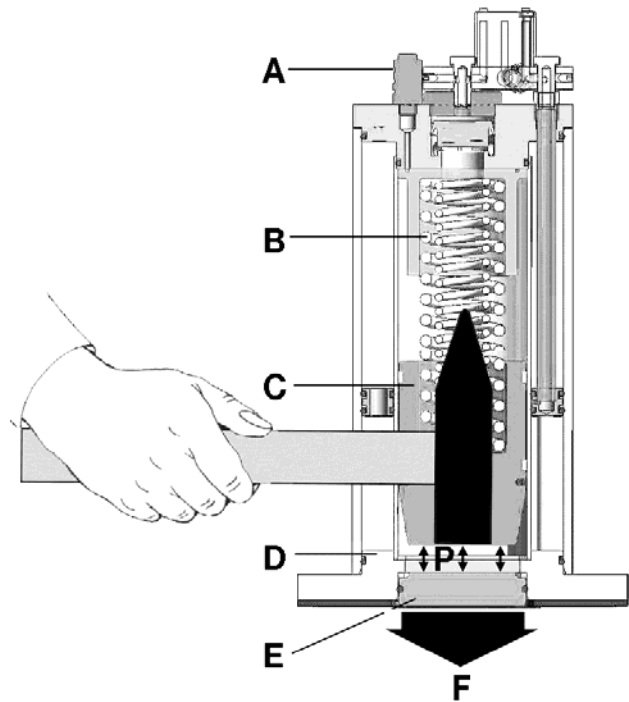

Special feature of PKL 740 (without illustration)

A 3/2-way valve and a quick air-exhaust valve are integrated in the valve head of the PKL 740. The control valve existing on customer's site can therefore be mounted at any distance from the PKL 740.

The pilot air supply must be connected laterally. A silencer is mounted on the exhaust outlet for the ventilation.

ST kit

The ST kit permits a continuous impact sequence with permanent compressed air supply.

EE kit

The EE kit reduces the sound level and creates a rubber hammer effect.

5 Transport and Storage



Check the packaging for possible signs of transport damage. In the event of damage to the packaging, check that the contents are complete and undamaged. If there is any damage, inform the shipping agent. Compare the scope of delivery with the delivery note.

The units are packed ready-to-install.
The type label is attached to the impactor.
Accessories and add-on parts are delivered unmounted, unless otherwise agreed.
Special transport conditions are not stipulated.
The units should be stored in a clean, dry environment.

PKL impactors must be oiled before going back into storage (pour machine oil into air inlet port and activate briefly).

Packaging

The packaging protects the unit from transport damages. The material of the packaging has been selected based on environmentally and disposal-friendly aspects and can therefore be recycled.

PKL 190, PKL 450 and PKL 740 must be screwed or clamped to a plate before operation. The impact plate must be inserted. Use ear protections

The storage temperature should be between -40 and +60°C. (This does not apply to the operating temperature).

Recycling the packaging reduces raw material consumption and the waste volume.

6 Installation



CAUTION

Ensure that the compressed air supply is shut off during installation or when working on the impactor and air supply lines.

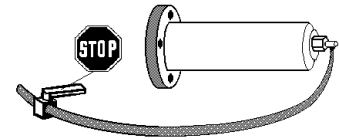

CAUTION

Pneumatic impactors PKL 190, PKL 450 and PKL 740 are open on the impact side. Ensure that the impact piston remains in the housing during installation!



CAUTION

Impactors of the series PKL 2100 and PKL 5000 must **always** be installed with impact plate and damper plate (included in the scope of delivery)!

PKL impactors are screwed to level reinforcement sections or weld-on consoles ($\pm 0.3\text{mm}$ flatness). Suitable weld-on consoles (see illustration on the right) are available from **NetterVibration** (see Accessories).

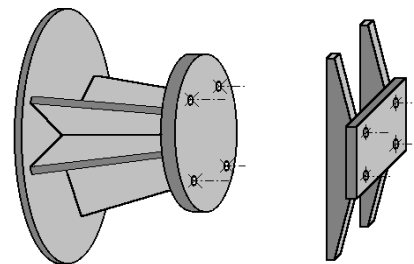

Weld-on plates must not be welded directly onto the panels of the construction, since they are too stiff. Use an intermediate layer of 1.5 times the sheet thickness (example A). Particularly in the type of attachment shown in A, the screws may break and are then difficult to replace, in contrast to example B.

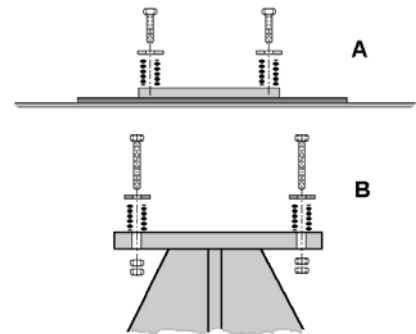

The fastening sets NBS serve to securely and permanently fasten the PKL impactors.

NetterVibration supplies these fastening sets NBS (screw, springs and matching washers) on request.



ST kit for PKL 740

The ST kit connects the control port with the piston chamber. The impactor continues to strike as long as compressed air is applied.

In this case only one air supply line is required.

See Assembly Instructions for ST kit.

Attention: For installations with automatic control ST, the silencer must be screwed on to the air supply.

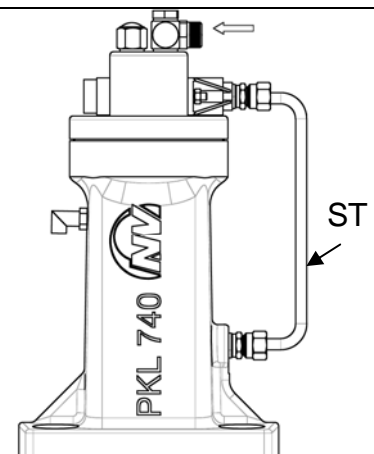

ST kit for PKL 190 and PKL 450

In this case a 3/2-way valve with air supply to **P** is required.

The ST kit connects the control port with the piston chamber.

The impactor strikes as long as air is applied to **P**. See Assembly Instructions for ST kit.

Circuit diagrams see chapter 6 "Installation".

Example: PKL 450.

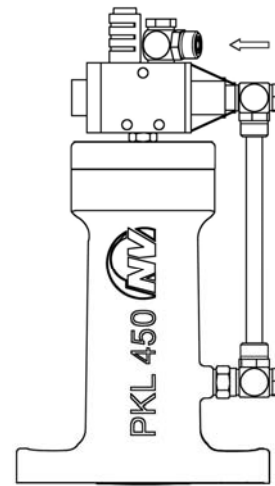

ST kit for PKL 2100 and PKL 5000

The ST control connects the control port with the piston chamber and is integrated in the PKL.

ST kit for PKL 5000

In this case a control valve has to be mounted onto the PKL. The control valve is internally connected to the piston chamber.

The impactor then continues to strike as long as compressed air is applied. See Assembly Instructions for ST kit.

The impact sequence can be set by means of a throttle (optionally).

Circuit diagrams see chapter. 6 "Installation".

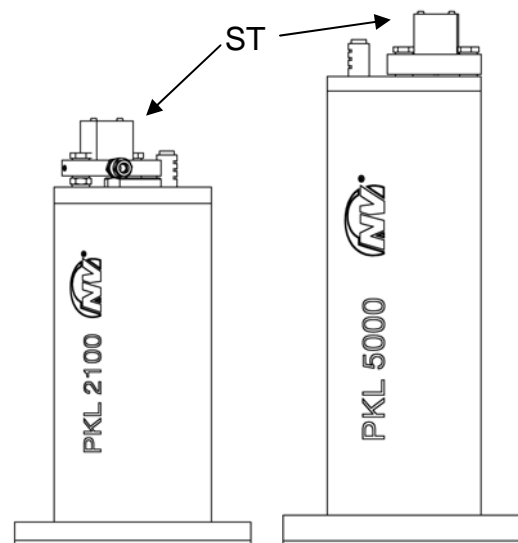

EE kit for PKL 190, PKL 450 and PKL 740

A spacer plate with a replaceable elastomer and O-ring is installed between impactor and mounting surface. See Assembly Instructions for EE kit.

Example: PKL 190.

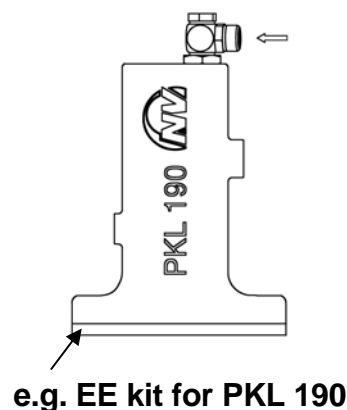

EE kit for PKL 2100 and PKL 5000

The piston hits against an impact plate. The air channel is integrated in the housing. The exhaust air escapes into the atmosphere via the silencer.

A 3/2-way air valve is required if the control valve at the customer's site is mounted at a distance of more than 15 m from the PKL.

If the impactor is fitted with the EE kit, the steel impact plate with damper ring and O-ring is replaced by an elastomer impact plate with O-ring.

PKL 2100 and PKL 5000 must always be installed with impact plate and damper plate.

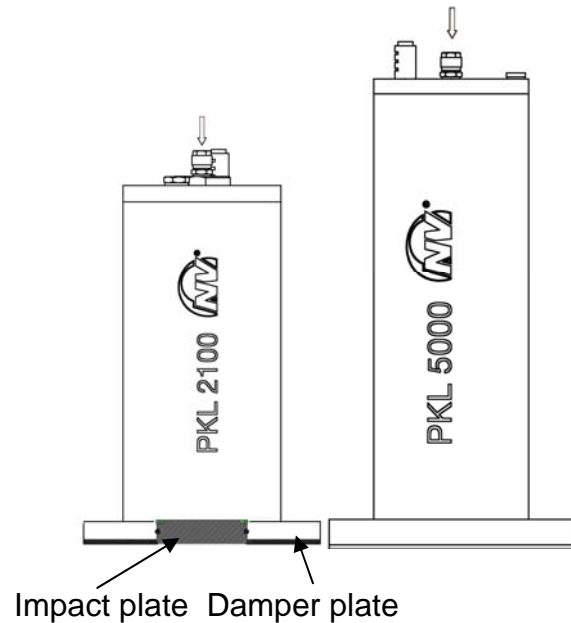

CAUTION

Use lock nuts or a locking fluid, e.g. Loctite 270, in order to prevent loosening. Also secure the compressed air supply lines with a suitable retention agent. Use the tightening torques shown in the table below. Higher tightening torques can lead to the fracturing of screws or tearing of threads. Incorrect attachment of screws can lead to detachment of the device due to vibration. This can result in personal injury and damage to material!

Recommended average tightening torques for screws property class 8.8 on PKL housings (screws as delivered, with no additional lubrication)

Type	Thread/hole pattern mm)	Tightening torque
PKL 190	M 10 / 90	51 Nm
PKL 450	M 12 / 90	87 Nm
PKL 740	M 12 / 50 x 100	87 Nm
PKL 2100	M 12 / Ø152	87 Nm
PKL 5000	M 16 / Ø152	215 Nm



CAUTION

When using fastening sets (NBS series) with screw or elastomer springs, the tightening torques are **lower**.

Please observe the information and instructions supplied with these accessories.

PKL 190 and PKL 450 with NBS

The PKL 450 with ST kit is first attached to the dampening set NBS 450, and then the lower ST screws are mounted.

Example: PKL 450

Dampening set NBS 450

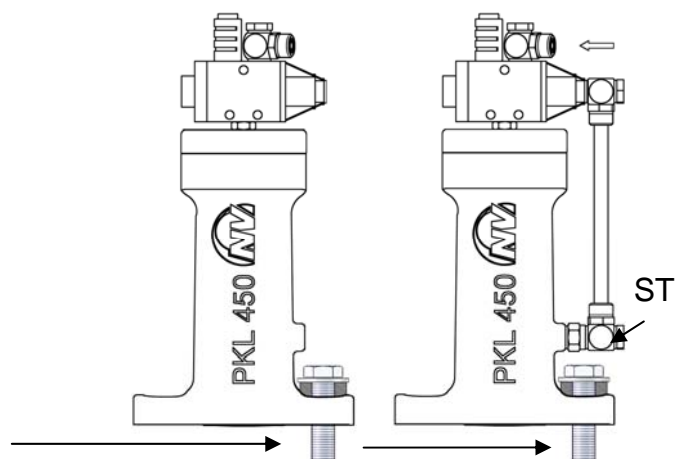

Installation PKL

A cock valve **1** to shut off the main line and a maintenance unit **2** are recommended for all installations.

The maintenance unit should consist of filter, regulator and mist lubricator. (see chapter. 3 „Technical Data, Drive medium “)

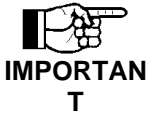

Connect the hoses of the PKL as shown on the pneumatic circuit diagrams!

Installations for PKL 190, PKL 450, PKL 2100 and PKL 5000

Standard installation:

A 3/2-way valve **3** must be used for the control.

Upon switching of the valve the piston chamber is ventilated and exhausted and the impactor is striking.

The impact sequence can be determined by a Netter electronic timer AP **4**. Electric or pneumatic controls are available on request.

The 3/2-way valve **3** can be installed at greater distances (up to 15 m) from the impactor.

Examples: PKL 450 and PKL 2100.

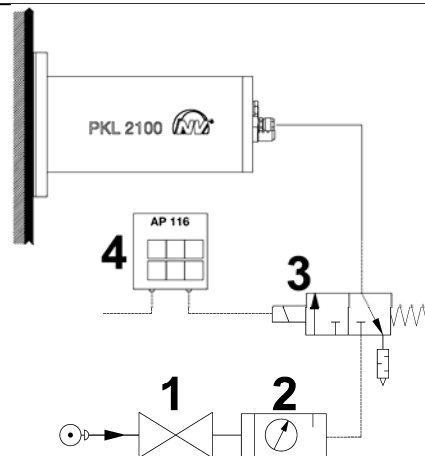
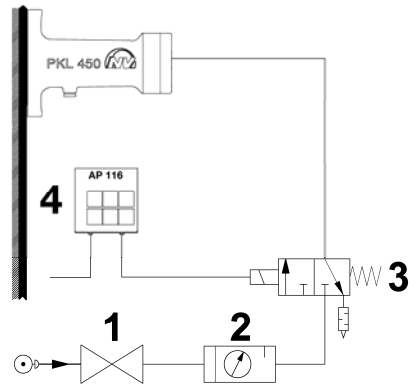

Installation with long supply line:

If the supply line **A** exceeds 15 m, an additional 3/2-way valve **9** and a throttle **6** must be installed.

Line **B** must have a minimum length of 1 m and during commissioning the throttle **6** must be adjusted so as to switch the 3/2-way valve **9** with time delay.

For this purpose the **Netter** start control can be installed (available on request) which includes all necessary components.

Example: PKL 190.

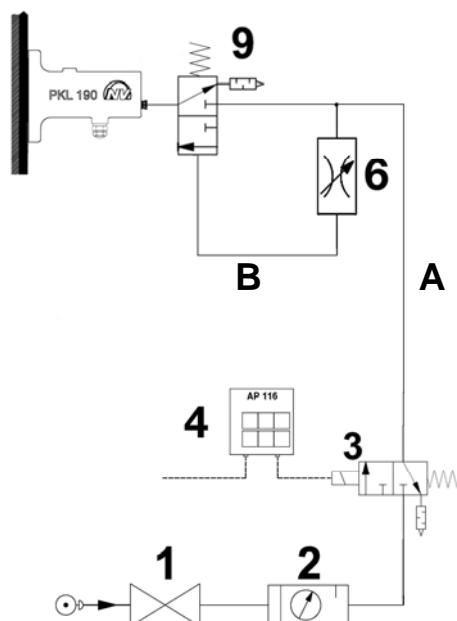

Installation of several PKLs:

It is possible to operate several impactors in parallel with just one control and one valve.

The length of the connecting lines from valve to the PKL must not exceed 1 m, otherwise the control piston or membrane in the unit will move too slowly and not reach the sealing final position.

The 3/2-way valve 3 can be installed at greater distances from the impactor if additional 3/2-way valves 9 are used.

If several PKLs are operated, the overall length of the air supply line must not exceed 50 m.

Example: PKL 450.

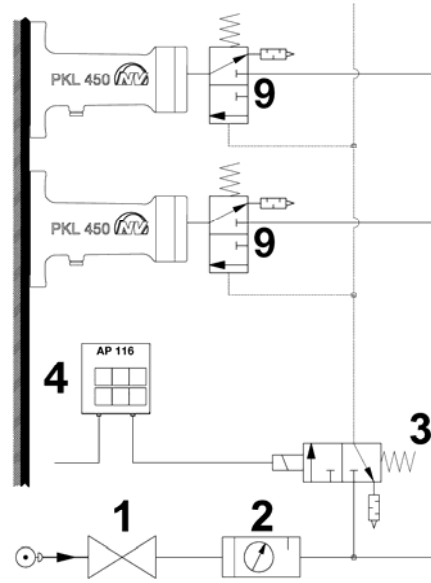

Installation with ST kit:

With an ST kit the PKL continues to strike as long as pressure is applied.

The PKL can then achieve an impact frequency of approx. one impact/second. This maximum impact sequence must be reduced to the max. permissible impact sequence (e.g. using a throttle valve 6 installed in the air supply line).

With an ST kit a PKL can be operated with a 2-, 3-, or 4-way valve 3, even if it is located at a greater distance (up to 50 m).

The length of the connecting lines from valve to PKL must not exceed 1 m, otherwise the control piston or the membrane in the unit will move too slowly and not reach the sealing final position.

Examples: PKL 450 and PKL 2100.

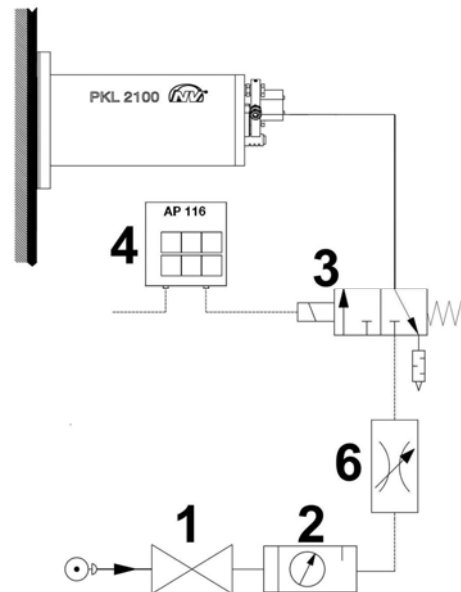
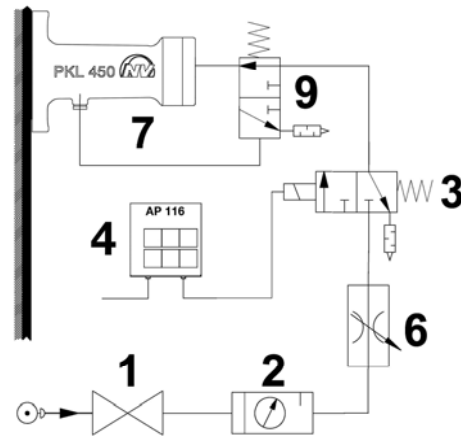

Installation with coupling to other functions:

If the PKL 740 is fitted with an ST kit, it can be coupled to another function without having to use a control or pulse generator. The adjoining illustration shows the coupling to an opening cylinder **8** on a weighing container. The impactor is not activated. Once the flap is opened, the impactor will strike at the frequency set by the throttle as long as the flap remains open.

Example: PKL 2100.

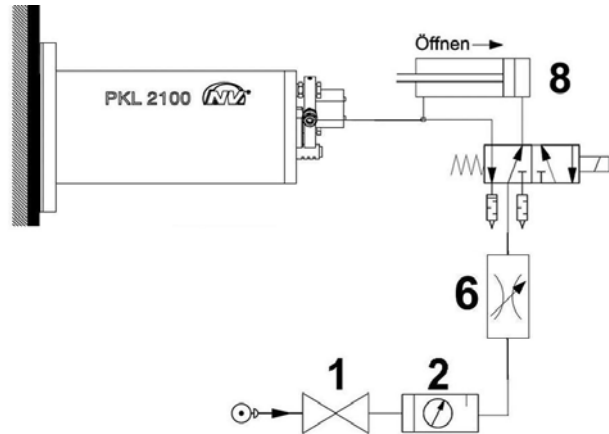

Installations for PKL 740

Standard installation:

The PKL 740 is the only PKL with integrated 3/2-way pneumatic valve in the valve head.

Upon switching of the valve the piston chamber is ventilated and exhausted and the impactor is striking.

The impact sequence can be determined by a Netter electronic timer AP 4. Electric and pneumatic controls are available on request.

The main air supply is constantly applied to the valve head. The control line from the activation valve existing on customer's site **3** and the impactor can be very long (e.g. 50 m). In case of long supply and control lines the charge time of the impactor can take several seconds. If the compressed air lines are long (e.g. 50 m), a pause and duty time of at least 5 seconds should be set on the electronic timer AP **4**. If shorter lines are used, these times can be reduced accordingly, e.g. to 2-3 seconds.

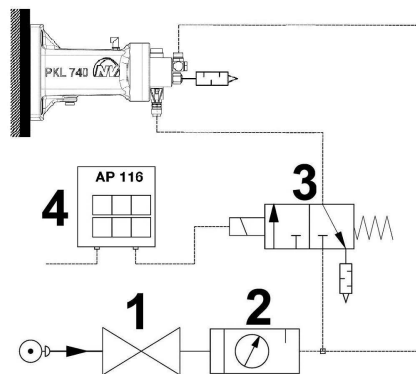

Installation of several PKL 740:

Parallel operation of several PKL 740 is possible with just one control and one valve.

In this case the overall length of the air supply line must not exceed 50 m.

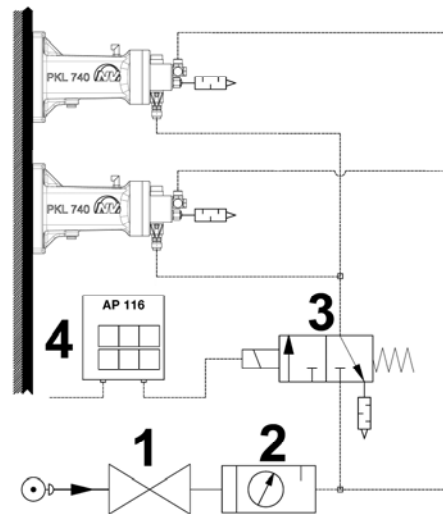

Installation with ST kit:

With an ST kit 7 the PKL continues to strike as long as pressure is applied.

The PKL can then achieve an impact frequency of several impacts/second. This maximum impact sequence must be reduced to the max. permissible impact sequence (e.g. using a throttle valve 6 installed in the air supply line)..

A PKL with ST-control 7 can be activated using a 2-, 3- or 4-way valve 5, even if it is mounted at a greater distance (possible up to 50m).

If a Netter electronic timer (AP) 4 is used, the PKL strikes several times during the duty time.

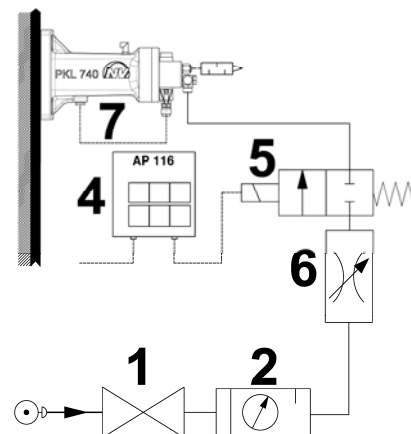

Installation with coupling to other functions:

If the PKL 740 is fitted with an ST kit, it can be coupled to other functions, without having to use a control or pulse generator. The adjoining illustration shows the coupling to an opening cylinder 8 on a weighing container. The impactor is not activated. Once the flap is opened, the impactor will strike at the frequency set by the throttle as long as the flap remains open.

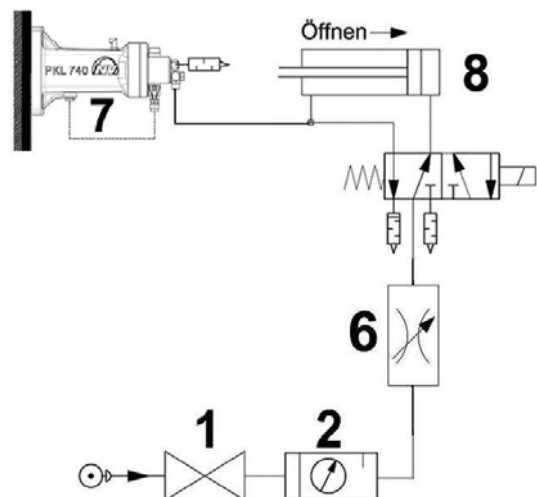

Recommended cross-sections for valves and hoses

PKL 190, PKL 450, PKL 740, PKL 2100 and PKL 5000:

Control lines, control valves: NW 6 × 1

Main air supply: NW 6 × 1



Use NW 6 for connection of the control valve to PKL and do not exceed a length of 15 m.

For simultaneous activation of several PKLs greater cross sections have to be used for the main air supply line.

For the activation of several PKL the total length of the compressed air supply lines must not exceed 50 m.

Check list for installation:

- 1) Consider expected operating temperature.
- 2) Install main cock and maintenance unit (filter, regulator, as required), valve and supply line.
- 3) Mount weld-on console (if necessary).
- 4) Install with fastening set (NBS).
- 5) Install PKL 2100 and PKL 5000 with damper plate.
- 6) Secure fastening screws with glue (e. g. Loctite).
- 7) Glue in air supply lines!
- 8) Observe information on hose length and nominal width.
- 9) Secure the unit against falling down!

7 Start-up / Operation



IMPORTANT

Lubricated compressed air is recommended for PKL impactors:

Fill mist lubricator with acid and resin free pneumatic oil, ISO viscosity class according to DIN 51519, VG 5 to VG 15.

Recommendation: Klüber "AIRPRESS 15" for temperatures up to 60°C.

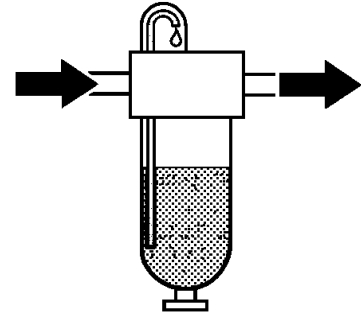

When selecting the lubricator, bear in mind that the air consumption of the PKL is very low. The selection of the lubricator is dependent on the number of impactors to be operated at the same time.

Units with 1/8" and 1/4" connectors are recommended. Larger units may not respond.

Set to the lowest number of drops.



IMPORTANT

ATTENTION:

Adjust the number of drops with the unit running.

Only after the mist lubricator has been adjusted and is functioning correctly, the device is ready for operation.



CAUTION

Impact frequency

Max. 10 impacts in succession at an impact frequency of 15 impacts/min and 180 impacts/h.

This impact sequence must not be exceeded.

Regulation of Impact Frequency:

PKL must be used for clocked operation only!

with ST control:

In a PKL with ST control the impact frequency can be regulated by means of the throttle.

without ST control:

The impact frequency must be regulated using an external control, e.g. with a 3/2-way valve and a Netter electronic timer AP

Regulation of Impact Strength:

The impact strength can be reduced by lowering the pressure (exception ST kit). Throttling the air supply (via a throttle, cut-off valve, etc.) will not reduce the impact strength, but will delay the charge time.

Check list for start-up:

- 1) Check hose connections before opening the compressed air supply.
- 2) If required, set the desired impact force on the pressure regulator (does not apply if ST kit is installed).
- 3) If the ST kit is installed, the frequency can be regulated using a throttle. Do not set faster than necessary (service life, noise pollution).
- 4) Adjust mist lubricator if existing.
- 5) After 1 hour of operation the compressed air lines, attachment and fastening screws should be checked and tightened if necessary. After this, the attachment and fastening screws and compressed air lines should be checked at regular intervals (generally once per month) and tightened if necessary.



CAUTION

8 Maintenance / Repair



Before starting inspection or service work, shut off the compressed air supply and protect it against unintentional activation!

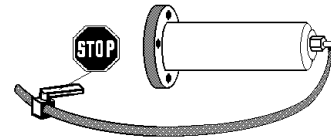

The drive medium must be clean (filter $\leq 5 \mu\text{m}$, class 3).
Unfiltered compressed air leads to high wear, blocked silencers or complete break-down of the impactor.
The maintenance intervals will be shorter.

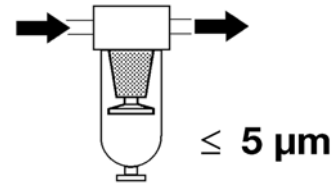

Filter empfohlen

Maintenance schedule

Maintenance must be performed on a monthly basis.



Screw connections	Screw connections should be checked and - if necessary – tightened and secured with Loctite after one hour of operation (after first commissioning) and then at regular intervals.
Check total number of impacts	After a maximum of 500.000 impacts a comprehensive service should be carried out during which all seals and guide rings should be replaced
Air supply lines	Check for kinks and ensure that the lines are free from obstructions. If necessary, clean the hoses and remove kinks.
Silencer	Clean and check function.
Check impacts	Check function.
Mist lubricator	Make sure that mist lubricator works correctly (contents decreasing? Number of drops/h?). Refill oil.
Filter of the maintenance unit	Empty filter if necessary, clean (wash out) filter insert or replace filter insert.



The maintenance intervals largely depend on the operating period and the cleanness of the drive medium. Especially in units driven by oil-free and / or dried compressed air, increased friction can create deposits which will slow down the function.

If this is noticed (performance loss or even standstill), the impactors should be cleaned and the sealing and guide rings replaced, if necessary. The maintenance intervals are reduced.

Cleaning the impactor:

When cleaning the impactor, it is necessary to remove and clean the piston. In case of wear, the guide rings and piston seals must be replaced. A special tool is necessary (available upon request) to insert the piston. Alternatively, maintenance, repair and comprehensive servicing can be carried out by **NetterVibration**.

9 Troubleshooting

Fault	Possible causes	Troubleshooting	Remedy
No function	Mounting surface not plane.	Pressure loss via O-ring.	Ensure mounting surface with flatness error $\pm 0,1$ mm!
	Malfunction of valve and control.	Check impactor without valve and control	Check 3/2-way valve and control, replace if necessary.
	Air supply	Check pressure. Check valve switching.	Adjust operating pressure. Replace valve if necessary.
No function with leakage from top	Seals are worn.	Check seals of knocking and control pistons (PKL 190).	Replace seals on the knocking and control pistons.
	General wear	Housing, membrane and control piston worn?	Replace affected parts and seals.
No function with leakage on the mounting surface	PKL not mounted correctly.	Check fastening screws.	Tighten fastening screws or replace if necessary.
	Mounting surface not even.	Check mounting surface.	Ensure mounting surface with flatness error $\pm 0,1$ mm!
		Check O-ring.	Insert O-ring into the groove and replace it if damaged.
No function with ST kit.	Operating pressure too low.	Check unit type. Check pressure.	Increase pressure.
Weak impact	Air supply	Check pressure	Adjust pressure.
	Control valve soiled	Check control valve.	Clean control valve or replace if necessary.
	Silencer soiled	Check silencer.	Clean silencer.
	Wear, leakage		Replace the seals.

10 Spare Parts

When ordering parts, please supply the following details:

1. Required quantity
2. Description and position of the spare part
3. Type of unit

11 Accessories

The following accessories are available for the pneumatic impactor PKL (upon request):

Description	Remarks
Fastening sets NBS	NBS 190 for PKL 190 NBS 450 for PKL 450 NBS 1, 2 and 5 for PKL 740 NBS 2100 for PKL 2100 NBS 5000 for PKL 5000 Screws, springs and matching lock washers for secure fastening.
ST kit	When using this type of control, the pauses between the individual impactor sequences must be long enough (see chapter 6).
Hose material and fittings	For compressed air supply (working air, pilot air), in various qualities and dimensions.
Way valves	Electrical, pneumatic, manual
Throttle valves	For cycle control on PKL with ST kit.
Maintenance units	Filter, regulator with pressure gauge, mist lubricator.
Netter electronic timers	Electrical (also for special voltages) or pneumatic controls.
Weld-on consoles	For round and rectangular containers, also for use on insulated containers, funnels etc.
Vacuum fixing devices, quick clamping devices	For quick relocation on containers etc.
Noise reduction	Hoods, covers, EE kit.
Safety suspension	Clamp with steel rope and snap hooks.
Netter start control	For long supply lines (>15m).
Special versions:	Flanges with different dimensions available at extra cost, high-temperature versions and further information on request.

12 Disposal

The parts are to be correctly disposed of, depending on the material.

Material specifications:

	PKL 190	PKL 450	PKL 740	PKL 2100	PKL 5000
Stainless steel					Reducer, ST tube, ST plate, ST connecting angle
Steel	piston, springs	piston, springs	piston, springs	impact plate, impact piston, springs, ST- tube	outer tube, inner tube, impact plate, top cover, flange, impact piston, springs
Aluminium	housing, pilot piston	housing, pilot piston	housing	inner tube, outer tube, reducer, top cover, flange, ST-Ring, ST-plate	
PTFE, PU, VITON, NBR	Spring guide, ring stop, seals	cover, seals	cover, seals, membranes	seals, dampening rings, dampening plates, impact plate -EE	seals, dampening rings, dampening plates, impact plate -EE
Valves: Brass, nickel-plated; Plastic					



All units can be disposed of through Netter GmbH.
The applicable disposal prices are available upon request.

13 Enclosures

Enclosure(s):
Declaration of incorporation



**Additional information available upon request:
Leaflet No. 27 (PKL), and others.**