



44

Netter Dosing Station Series *DosyPack*



- Exact dosing
- High conveying performance
- Gentle and uniform dosing
- Adjustable fine or coarse flow
- All product-carrying parts made of stainless steel 1.4301
- High surface quality
- Quick and easy to clean



*DosyPack*4



DosyPack 40



DosyPack 56



Netter Dosing Station Series *DosyPack*

Example	Product Characteristics		Feed Rate [g/s]		Noise Level [dB(A)]
	Grain Density [kg/dm ³]	Grain Size [mm]	<i>DosyPack</i> 4	<i>DosyPack</i> 25 bis 80	
Sand	1,54	0 - 1	0 - 20	0 - 260	56 - 75
Granulate	0,70	1 - 3	-	0 - 150	56 - 75
Plastic caps	0,20	Ø 10	-	0 - 25	56 - 73

The technical data relate to the examples given and can vary, depending on the product.

Type	A [mm]	B [mm]	ØC [mm]	D [mm]	E [mm]	□F [mm]	G [mm]	V (Container volume) [l]	Weight [kg]
<i>DosyPack</i> 4	420	480	200	190	175	290 × 150	105	4	5,5
<i>DosyPack</i> 25	729	710	381	241	190,5	430 × 280	261	25	15,0
<i>DosyPack</i> 40	729	860	381	241	190,5	430 × 280	261	40	16,8
<i>DosyPack</i> 56	805	844	533	241	190,5	430 × 280	261	56	26,3
<i>DosyPack</i> 80	805	994	533	241	190,5	430 × 280	261	80	29,5



Dosing port at the silo outlet

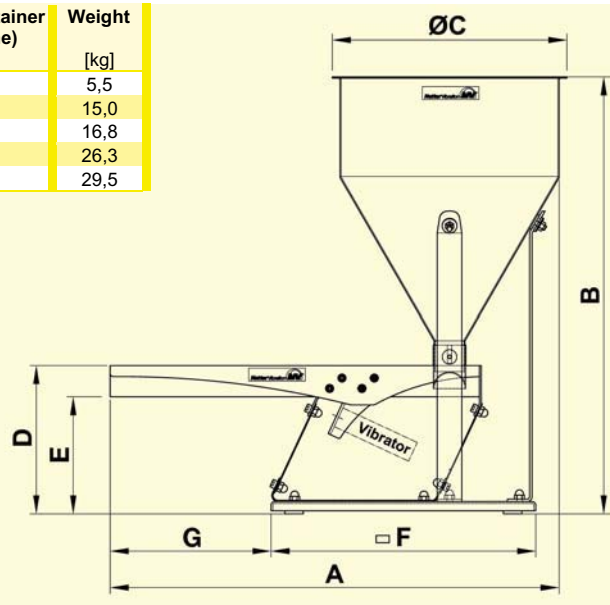

Applications

DosyPack dosing stations are particularly suitable for the fast and exact dosing of all types of bulk material, or as feeders for optical sorting facilities. Gentle dosing is possible for especially sensitive products.

Design and functioning principle

The dosing station basically consists of a conveyor channel mounted on leaf springs and a silo. All product-carrying parts are made of brushed stainless steel ($R_a=0,25$, $R_z=1$), all other parts are made of corrosionresistant and physiologically harmless materials.

Because of the functional design *DosyPacks* are fast and easy to clean. This allows it to be used even under the extreme hygienic conditions demanded by the chemical, pharmaceutical and food industries.

The flow rate can be varied with the dosing port at the silo outlet.

Pneumatic linear vibrators series NTS and NTK may be selected for driving. They work without running on, so that the product flow is immediately interrupted, once the vibrators are switched off.

The exact feed quantity is regulated by adjusting the frequency and amplitude of vibration. Both can be independently adjusted. Increasing the supply pressure causes an increase in the frequency. The amplitude can be adjusted by regulating the optional throttle.

A multi-directional valve is required for operation (not supplied).

In addition to the standard versions, series *DosyPack* dosing stations are also available in customized designs. Furthermore, all individual components can be supplied separately.

Permissible operating conditions

Drive medium:

Compressed air or nitrogen (filter $\leq 5 \mu\text{m}$), preferably with oil mist

Operating pressure:

2 bar to 6 bar

Ambient temperature:

5°C to 60°C

NetterVibration offers the accessories required for the mounting, installation, control and monitoring of vibrators and impactors.

Netter provides solutions.

Consult our experienced application technicians.

Netter GmbH

Germany

Fritz-Ullmann-Str. 9
55252 Mainz-Kastel
Tel. +49 6134 2901-0
Fax +49 6134 2901-33

Switzerland

Erlenweg 4
4310 Rheinfelden
Tel. +41 61 8316200
Fax +41 61 8311291

Poland

Al. W. Korfantego 195/17
40-153 Katowice
Tel. +48 32 2050947
Fax +48 32 2051572

www.*NetterVibration*.com
info@*NetterVibration*.com